

MODEL 10914 AND 10914S PANEL COMPONENTS

Panel Assembly

10914

P/N: 05192

10914S

P/N: 05216

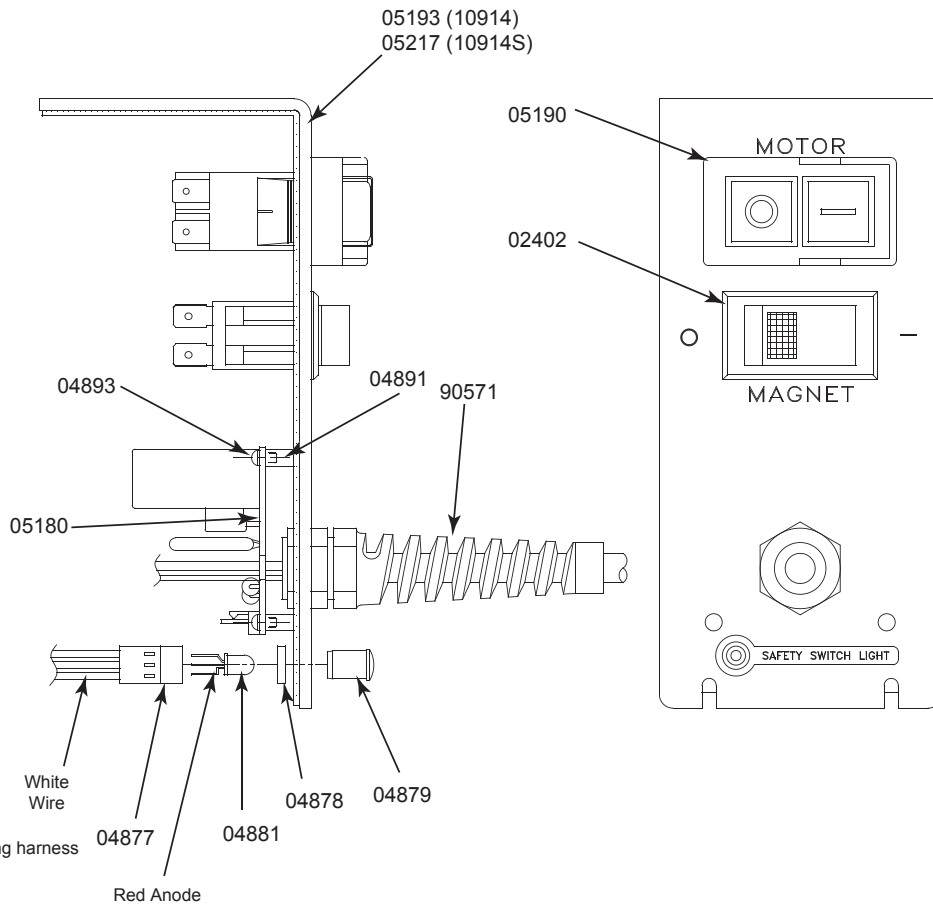

10914 & 10914S Panel Components

Part #	Description	Qty	Part #	Description	Qty
02402	Maget Switch	1	05180	Circuit Board	1
04877	Wire Harness	1	05190	On/Off Switch	1
04878	Spacer LED	1	05193	Faceplate (10914)	1
04879	Lens Cover	1	05204	Wire Harness Jumper	1
04881	LED	1	05207	Wire Harness Ground	1
04891	Spacer	3	05217	Faceplate (10914S)	1
04893	Phillips Screw	3			

MODEL 10914 & 10914S HOOK UP DIAGRAM

