

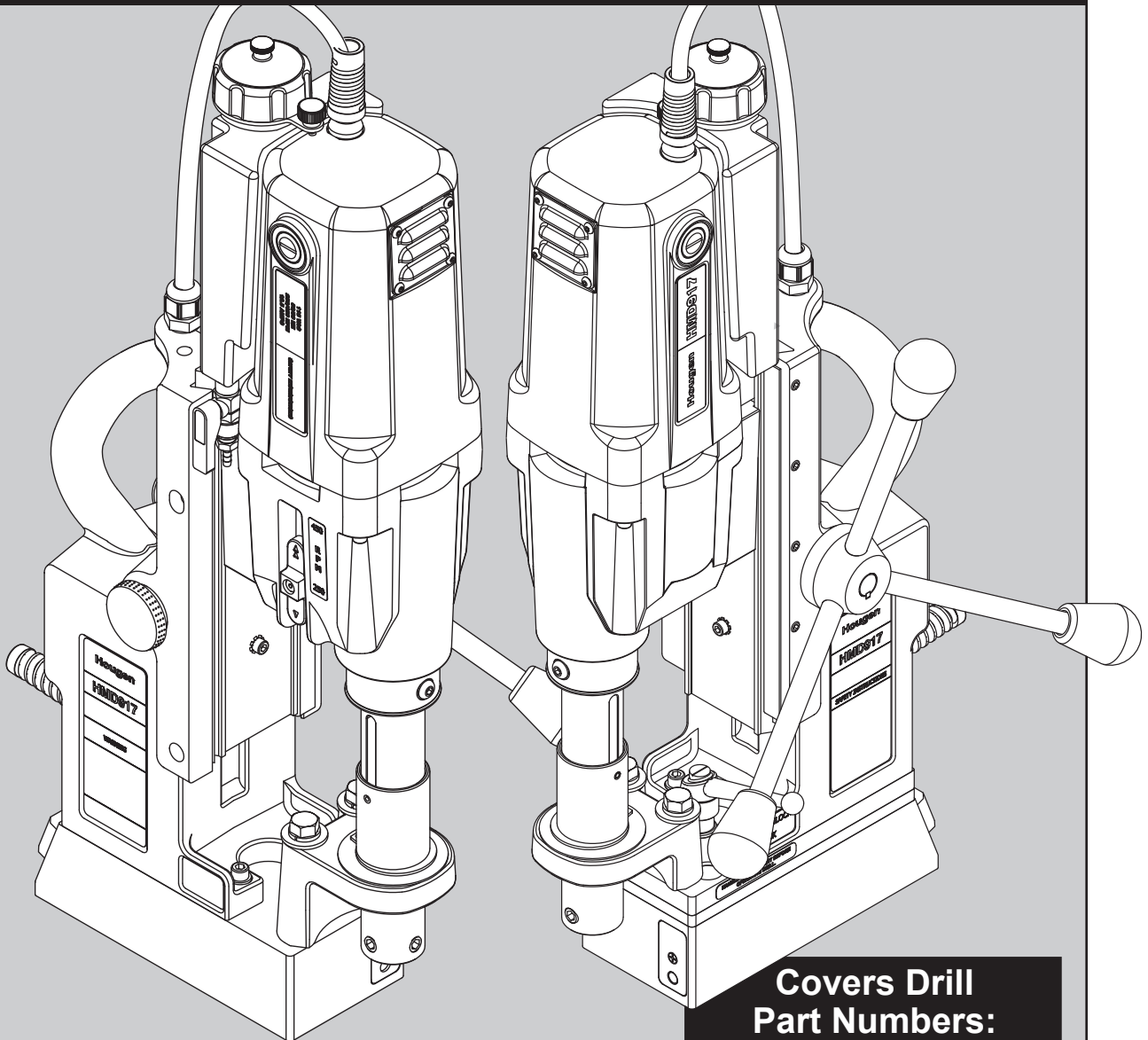

# OPERATOR'S MANUAL

## HMD917 SERIES PORTABLE MAGNETIC DRILL



**Covers Drill  
Part Numbers:**

0917202	0917302	0917402
0917204	0917304	0917402

# HOUGEN® PORTABLE MAGNETIC DRILL MODEL HMD917 SERIES

## Welcome to Hougen

Congratulations on your purchase of the Hougen® Portable Magnetic Drill. Your model is designed to produce superior holes quickly and efficiently. Through constant innovation and development, Hougen is committed to provide you with hole producing tools and products to help you be more productive.

Before attempting to operate your new Portable Magnetic Drill, please read all instructions first. These include the Operator's Manual and Warning Label on the unit itself. With proper use, care, and maintenance, your model will provide you with years of effective hole drilling performance. Once again, thank you for selecting our product and welcome to Hougen.

## Specifications

Cutter Type.....Hougen "12,000-Series"  
 Hole Capacity.....7/16" to 2-3/8" (12mm-60mm)  
 Depth of Cut.....3" (76mm)  
 Motor.....250 and 450 RPM, 6.25A  
 Swivel Area.....1-1/8" W x 1-3/8" L  
 Net Weight.....46 lbs. (20.9 kg)  
 Swivel Base: 50 lbs. (29.9 kg)

The HMD917 is offered in many versions. Refer to the Serial/Part number Label on your housing to direct you to the correct breakdown.

## Part Number

Covers All 230V HMD917 Models

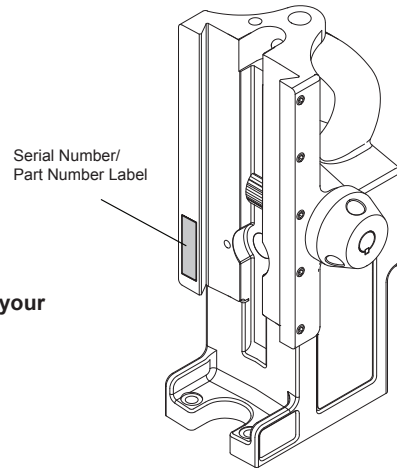

## UNPACKING YOUR NEW MAGNETIC DRILL

1. Open shipping carton and remove the literature and hardware packages.
2. **Read and Follow All Instructions** before attempting to operate your new Magnetic Drill.
3. Complete and mail the Product Registration Card [now](#). It is important that Hougen Manufacturing, Inc. have a record of product ownership.
4. Open hardware package and check contents.
  - 10565** 1/8" Hex wrench for Gib Adjustment
  - 10569** Feed handles (3)
  - 04532** Feed handle knobs (3)
  - 10730** Safety chain
  - 24166** 7/32" Hex wrench
  - 13013** 5/32" Allen wrench
5. Using the handle of Magnetic Drill, lift unit out of the shipping case.
6. Remove all packing and securing material from the drill unit.
7. Screw the three Knobs into the three Feed Handles and then screw Handles into the Hub Assembly. Do not over tighten or may strip the knobs.
8. Your Magnetic Drill was factory adjusted prior to shipping. Check to make sure that all gib adjustment screws, motor mount screws, front support bracket screws, and magnet mounting screws are snug and have not vibrated loose in transit.
9. Your new Magnetic Drill comes complete with arbor mounted. The 3/4" diameter arbor bore fits all 3/4"-shank "12,000-Series" Hougen Cutters.

**Reread Safety Warnings listed in the Operator's Manual and on the drill unit to avoid injury. Follow operating procedures.**

## INDEX

Welcome to Hougen	2	Control Panel Breakdown	10
Safety Instructions	3-4	Motor Slide Assembly Breakdown	11
<b>Safety Chain Instructions</b>	<b>4</b>	Motor Breakdown	12
Operation of Controls	5	Maintenance	13
Safety Switch Indicator Light	5	Adjustment of Gibs & Arbor Adjustment	13
Pilot Light Switch	5	Arbor Removal & Installation	14
Installing Hougen Cutters	6	Swivel Base Instructions	14
Operating Instructions	6	Hints & Remedies for Holemaking	15
Coolant Bottle Assembly & Breakdown	7	Commercial / Industrial Limited Warranty	16
HMD917 Assembly Breakdown	8-9	Authorized Warranty Repair Centers	16

# WARNING



Cutters are sharp. Wear gloves when installing or removing cutter from arbor. Do not grab a rotating cutter.



To prevent electric shock, do not use power tools near wet areas, or where power tool may become wet.

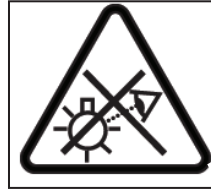

Do not stare at operating light.

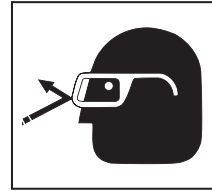

Always wear eye protection while using cutting tools, or in the vicinity of cutting.



The slug is ejected at the end of the cut. Do not aim cutter or arbor so that ejected slug may hit someone around, or below you.

## IMPORTANT SAFETY INSTRUCTIONS



### WARNING:

Read all safety warnings, instructions, illustrations and specifications provided with this power tool. Failure to follow all instructions listed below may result in electric shock, fire and/or serious injury.

### 1. Work Area Safety

- a) Keep your work area clean and well lit. *Cluttered or dark areas invite accidents.*
- b) Do not operate power tools in explosive atmospheres, such as in the presence of flammable liquids, gases or dust. *Power tools create sparks which may ignite the dust or fumes.*
- c) Keep children and bystanders away while operating a power tool. *Distractions can cause you to lose control.*

### 2. Electrical Safety

- a) Power tool plugs must match the outlet. Never modify the plug in any way. Do not use any adapter plugs with earthed (grounded) power tools. *Unmodified plugs and matching outlets will reduce risk of electrical shock.*
- b) Avoid body contact with earthed or grounded surfaces such as pipes, radiators, ranges and refrigerators. *There is an increased risk of electric shock if your body is earthed or grounded.*
- c) Don't expose power tools to rain or wet conditions. *Water entering a power tool will increase the risk of electric shock.*
- d) Do not abuse the cord. Never use the cord for carrying or unplugging the power tool. Keep cord away from heat, oil, sharp edges or moving parts. *Damaged or entangled cords increase the risk of electric shock.*
- e) When operating a power tool outdoors, use an outdoor extension cord suitable for outdoor use. *Use of cord suitable for outdoor use reduces the risk of electric shock.*
- f) If operating a power tool in a damp location is unavoidable, use a residual current device (RCD) protected supply. *Use of an RCD reduces the risk of electric shock.*

### 3. Personal Safety

- a) Stay alert, watch what you are doing and use common sense when operating a power tool. Do not use a power tool while you are tired or under the influence of drugs, alcohol, or medication. *A moment of inattention while operating power tools may result in serious personal injury.*
- b) Use personal protective equipment. Always wear eye protection. *Protective equipment such as dust mask, non-skid shoes, hard hat or hearing protection used for appropriate conditions will reduce personal injuries.*

- c) Prevent unintentional starting. Ensure the switch is in the off-position before connecting to power source and/or battery pack, picking up or carrying the tool. *Carrying power tools with your finger on the switch or energizing power tools that have the switch on invites accidents.*
- d) Remove any adjusting keys or wrench before turning the power tool on. *A wrench or a key that is left attached to a rotating part of the power tool may result in personal injury.*
- e) Do not overreach. Keep proper footing and balance at all times. *This enables better control of the power tool in unexpected situations.*
- f) Dress properly. Do not wear loose clothing or jewelry. Keep your hair and clothing away from moving parts. *Loose clothes, jewelry or long hair can be caught in moving parts.*
- g) If devices are provided for the connection of dust extraction and collection facilities, ensure these are connected and properly used. *Use of dust collection can reduce dust-related hazards.*
- h) Do not let familiarity gained from frequent use of tools allow you to become complacent and ignore tool safety principles. *A careless action can cause severe injury within a fraction of a second.*
- i) Always use safety chain. *Mounting can release.*

### 4. Power Tool Use and Care

- a) Do not force the power tool. Use the correct power tool for your application. *The correct power tool will do the job better and safer at the rate for which it is designed.*
- b) Do not use the power tool if the switch does not turn it on or off. *Any power tool that cannot be controlled with the switch is dangerous and must be repaired.*
- c) Disconnect the plug from the power source and/or remove the battery pack, if detachable, from the power tool before making any adjustments, changing accessories or storing power tools. *Such preventative safety measures reduce the risk of starting the tool accidentally.*  
*(Continued on page 4)*

**Save all warnings and instructions for future reference.**

## IMPORTANT SAFETY INSTRUCTIONS

- d) Store idle power tools out of reach of children and do not allow persons unfamiliar with the power tool or these instructions to operate the power tool. *Power tools are dangerous in the hands of untrained users.*
- e) Maintain power tools and accessories. Check for misalignment or binding of moving parts, breakage of parts and any other condition that may affect the power tool's operation. If damaged, have the power tool repaired before use. *Many accidents are caused by poorly maintained power tools.*
- f) Keep cutting tools sharp and clean. *Properly maintained cutting tools with sharp cutting edges are less likely to bind and are easier to control.*
- g) Use the power tool, accessories and tool bits etc. in accordance with the instructions, taking into account the working conditions and the work to be performed. *Use of the power tool for operations different from those intended could result in a hazardous situation.*
- h) Keep handles and grasping surfaces, clean and free from oil and grease. *Slippery handles and grasping surfaces do not allow for safe handling and control of the tool in unexpected situations.*

### 5. Service

- a) Have your power tool serviced by a qualified repair person using only identical replacement parts. *This will ensure that the safety of the power tool is maintained.*

## ADDITIONAL SAFETY INSTRUCTIONS

### Safe Electrical Connection

Your Drill is rated for use on 115VAC or 230V at 50-60Hz. Do not attempt to use drill on power sources rated other than this.

### Plugs and Receptacles

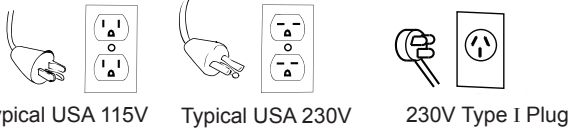

Wet electrical connections are shock hazards. To prevent the cutting fluid from traveling along the cord and contacting the plug or power outlet, tie a drip loop as shown. Also elevate extension cords or gang box connections.



### Extension Cords

Use only 3-wire extension cords that have a 3-prong grounding type plug and 3-pole receptacles that accept the tool's plug. Replace or repair damaged cords. Make sure the conductor size is large enough to prevent excessive voltage drop which will cause loss of power and possible motor damage.

LENGTH OF CORD, FEET	RECOMMENDED WIRE GAUGE	RECOMMENDED WIRE GAUGE
	115V MOTOR 10 - 12 AMPS	230V MOTOR 5 - 6 AMPS
Up to 25	16	18
26 - 50	14	18
51 - 100	10	16
101 - 200	8	14
201 - 300	6	12
301 - 500	4	10

### Outdoor Extension Cord Use

When tool is used outdoors, use only extension cords intended for use outdoors and so marked.

### Additional Safety Precautions

Arbor and cutter should never be used as a handhold or handle. Keep hands and clothing away from all moving parts. Do not use Houghen Cutters where ejected slug might cause injury (slug ejected at end of cut). Also, adhere to all operating instructions. Do not drill through any surface that may contain live electrical wiring. Drilling into a live wire could cause exposed metal parts of the drill to be made live. Remove chips wrapped around cutter and arbor after each hole. With motor off and power disconnected, grasp chips with leather gloved hand or pliers and pull while rotating counterclockwise. Should the cutter become jammed in the work, stop the unit immediately to prevent personal injury. Disconnect the drill from the power supply and loosen jammed cutter by turning the arbor counterclockwise. Never attempt to free the jammed cutter by starting the motor. Service at authorized repair center only.

### Operating Near Welding Equipment

**DO NOT** operate this unit on the same work surface that welding is being performed on. Severe damage to the unit, particularly the power cord, could occur. This could also result in personal injury to the operator.

### Circuit Breaker (If Applicable)

Changing of the circuit breaker to a higher amp rated breaker, or bypassing the circuit breaker is not recommended and will void product warranty.

### Circuit Breaker Operation (If Applicable)

The circuit breaker is a thermal breaker. When it reaches the higher temperature rating it will trip and cause the unit to shut down. This is a protective device and can be reset after 5 to 10 minutes. To reset the breaker, press the breaker button back in. If it does not reset, let the unit cool a little longer until you can push the button in and it stays in position.

**Save all warnings and instructions for future reference.**

## SAFETY CHAIN INSTRUCTIONS

A safety chain should **ALWAYS** be used whenever operating the drill.

The safety chain prevents the drill unit from falling, in the event of a power failure or if the magnet breaks loose from the work surface. The safety chain attaches to the drill by running the chain thru the D-Ring on the back of the unit and then continuing around the material and/or work surface. Adjust the chain so it is tight and secure. Please refer to the diagram.

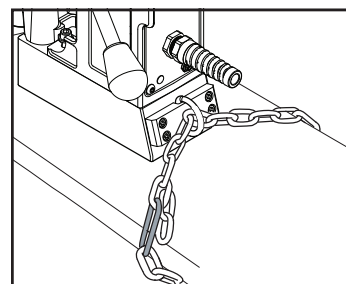

# OPERATION OF CONTROLS BEFORE INSTALLING HOUGEN CUTTER

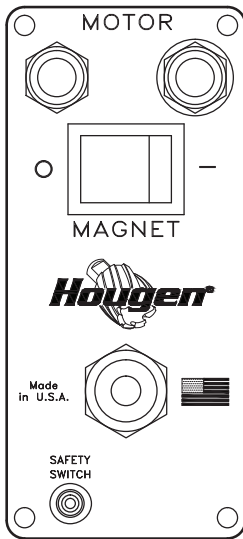

CONTROL PANEL SWITCH PLATE

**IMPORTANT:** Before turning on the machine, it is important that the operator understands the interrelated functions of the SAFETY SWITCH, MAGNET SWITCH, AND MOTOR SWITCHES. **READ SAFETY SWITCH INDICATOR LIGHT INSTRUCTIONS.**

**SAFETY SWITCH** — Located in base of drill. Enables motor operation only when magnet is properly seated on a clean and flat work surface. Turns motor off if switch detects lift of unit.

**MAGNET ON/OFF SWITCH** — Energizes and De-energizes the magnetic base and activates the safety switch. Motor can now be started by pushing the motor START switch.

**MOTOR START/STOP SWITCHES** — Starts and stops the motor

1. Place Magnetic Drill on clean, flat steel plate that is at least 3/8" thick.
2. Plug unit into proper AC power source. **DO NOT use with DC Power.**
3. Locate the Magnet **ON** and **OFF** switch and the motor **STOP** and **START** switch.
4. **NOTE: A loss of power will de-energize the magnetic base and deactivate the motor. When power is restored, the magnet will reenergize, however, the motor START switch must be depressed before the motor will start.**

## SAFETY SWITCH INDICATOR LIGHT

**\*\* SAFETY SWITCH LIGHT WILL COME ON AND REMAIN ON WHILE DRILL IS PLUGGED IN \*\***

The Safety Switch Indicator Light is a Standard Safety Feature on Hougen portable magnetic drills. Its purpose is to inform the user that the lift detector switch is activated.

### If light is Green:

In normal operation the safety switch light will be green. Motor "On" and "Off" Switches function normally.

### If light is Red:

A condition with the safety switch exists that needs to be corrected. Possible causes:

- Safety Switch is defective. Have drill serviced.
- Uneven work surface or material. Check work surface for flatness.
- Dirt or chips under magnet. Clean work surface.

### Testing Safety Switch:

Before operating the drill always test the safety switch. To test switch...place drill on work surface and plug into the outlet. Rock drill so magnet lifts off work surface. Safety Switch Light should change from green to red. If light stays green or red, a problem exists with the safety switch that must be corrected. (ie...safety switch defective, safety plunger in the base of magnet is stuck in position, etc.) Please correct and retest before operating drill.

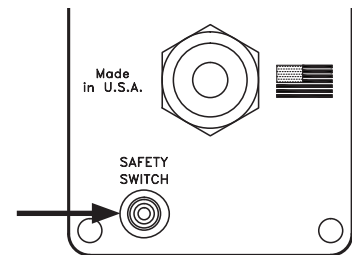

CONTROL PANEL SWITCH PLATE

**Material must be a least 3/8" thick. Material thinner than 3/8" will cause a "weak" magnet condition. HOUGEN MANUFACTURING RECOMMENDS THAT CONDITIONS ARE CORRECTED SO LIGHT IS GREEN. THIS ALLOWS FOR THE UNIT TO BE OPERATED IN A SAFE MANNER.**

For any questions please contact Hougen Manufacturing's Technical Service at (810) 635-7111.

## INSTALLING HOUGEN CUTTER IN ARBOR

1. Disconnect from power source and remove T-Handle wrench from holder at top of drill.
2. Lay drill on its side with feed handles up or be sure Arbor clears table if unit is in normal operating position.
3. Turn Feed Handles until cutter mounting set screws are exposed and completely remove the set screws.
4. Insert proper pilot in shank end of Hougen Cutter.
5. Insert Hougen Cutter until flat on cutter shank is aligned with set screw holes and is exactly perpendicular to axis of set screw holes.
6. Insert set screws and tighten. Check to be certain that cutter is secure.

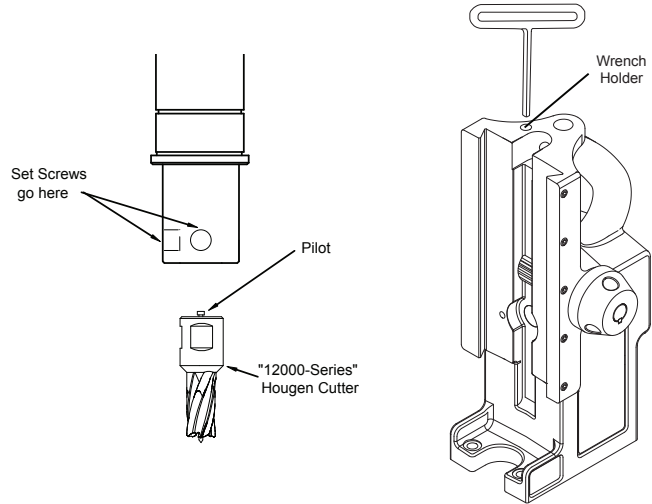

## OPERATING INSTRUCTIONS

Always remember that the magnet's holding power is directly related to the workpiece thickness and surface condition. Since magnetic attraction diminishes with thinner material or rough surfaces, mechanical clamping of drill unit to the workpiece should be used when cutting thin material (3/8" or less) or material with uneven surfaces.

1. Make sure workpiece and bottom of magnet are free of chips, oil, etc.
2. Verify Safety Switch works properly (See Safety Switch Indicator Light Section on pg. 5)
3. Position drill by sliding it and gently feeding Arbor so that pilot point is touching center of hole to be drilled.
4. **Secure unit to workpiece with safety chain.**
5. Turn magnet "ON" by pressing the magnet ON switch.
6. Turn Feed Handle, raising the cutter until the pilot is above the work surface.
7. Fill coolant reservoir or fill attached coolant bottle if applicable.
8. Make certain that cutter is clear of workpiece and turn motor "ON" by pressing the motor START switch.
9. Feed Hougen Cutter slowly into workpiece. Only after cutting path is established to a depth of about 1/16" can full force be applied to feed handles.
10. Ease up on feed pressure as cutter starts breaking through.
11. At conclusion of cut, turn motor "OFF" by pressing motor STOP switch. Turn Feed Handles to raise Arbor thereby ejecting the slug if it hasn't already fallen free.
12. Turn magnet "OFF" by pressing the magnet OFF switch.
13. **Disconnect from power source.**
14. If necessary, remove chips from cutter and magnet, preferably wearing leather work gloves and/or with pliers. Disconnect safety chain and you are ready to move unit to new drilling position.

**When drilling, especially in horizontal or overhead positions, always apply feed pressure toward the work surface. Never pull away from the work surface as this can weaken magnetic holding power.**

Use handles to feed toward work surface

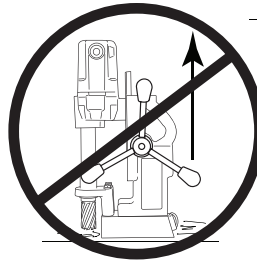
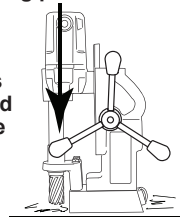

**Never pull handles away from work surface.**

### Selecting and Operating Speeds

## HMD917 RECOMMENDED RPM'S

### 450 RPM

7/16" - 1" Dia. (12mm - 25mm)

### 250 RPM

1-1/16" - 2-3/8" Dia. (26mm - 60mm)

RPM recommendations are based on using your HMD917 drill with Hougen "12,000-Series" H.S.S. Cutters. The RPM's do not represent optimum speeds for any given cutter diameter and application. For more information refer to Hougen's Speed & Feed Calculator located on Hougen.com, or call 1-800-426-7818 for Technical Support.

## OPERATION OF CUTTING FLUID RESERVOIR

1. With Magnetic Drill in operating position, turn the feed handles so that cutter and pilot are above the work surface.
2. With magnet turned ON & motor OFF, fill reservoir by introducing cutting fluid through slots in Arbor. **Cutting fluid should not leak out.**
3. Test metering capabilities of Arbor/Cutter/Pilot assembly (magnet ON - motor OFF) feeding the Arbor gently toward work surface until pilot is pushed up into Cutter, thus allowing fluid to filter down onto work surface through groove in pilot.
4. For proper lubrication, all fluid in reservoir should empty onto work surface in no less than 15 seconds and no longer than 30 seconds.
5. Reservoir holds enough coolant for cutting approximately one hole.  
\* This method of using coolant can also be used for an attached coolant bottle if the bottle is lost.
6. For horizontal or drilling overhead holes, use Slick-Stik Lubricant.

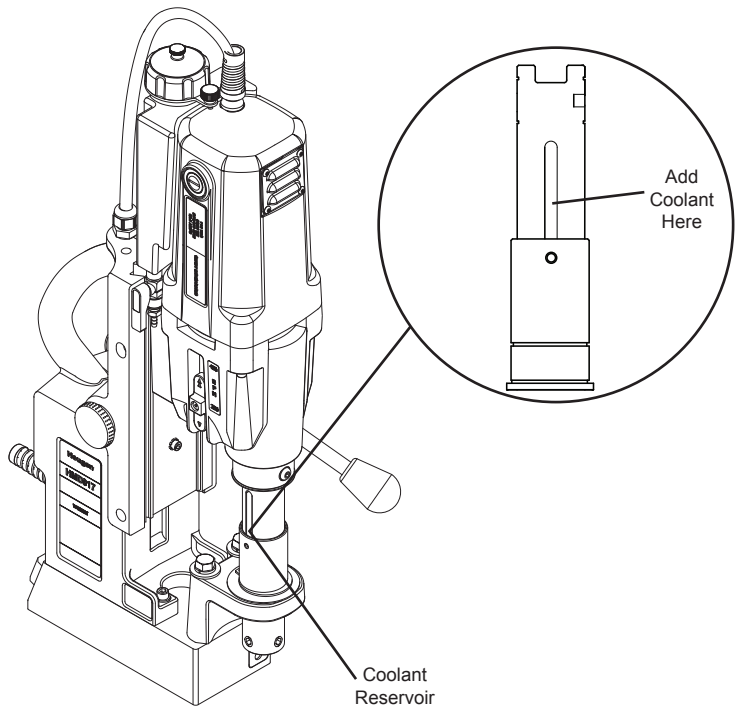

## COOLANT BOTTLE ASSEMBLY

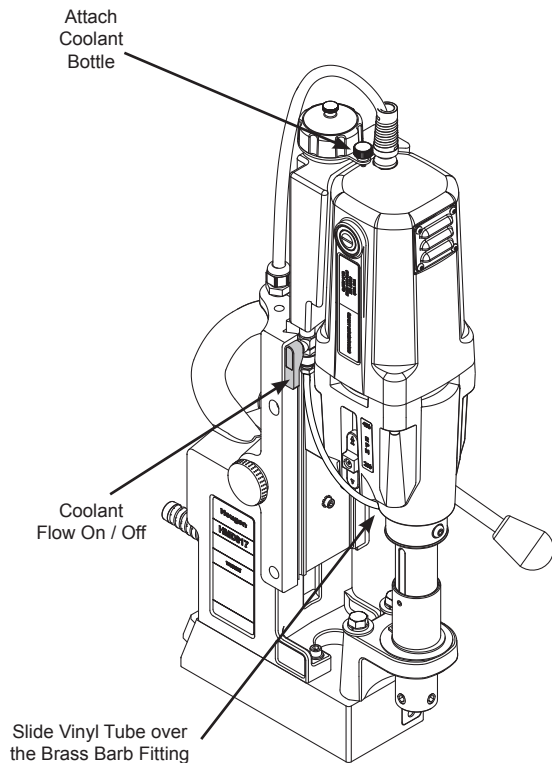

### 07950 Coolant Bottle Assembly

Part #	Description
08255	Coolant Bottle
08061	Coolant Bottle Bracket
41044	SCR-BHC 10-32 x 3/8
05065	Ball Valve
05067	Brass Barb Fitting (bottom of the bottle)
40304	Vinyl Tube
24124	Cap - Coolant Bottle

# HMD917 MAG BASE DRILL 230V

Motor Assembly  
(see page 12)

Coolant Bottle Assembly  
(see page 7)

Motor/Slide Assembly  
(see page 11)

Control Panel Assembly  
(see page 10)

## #4 - Coolant Arbor Assembly

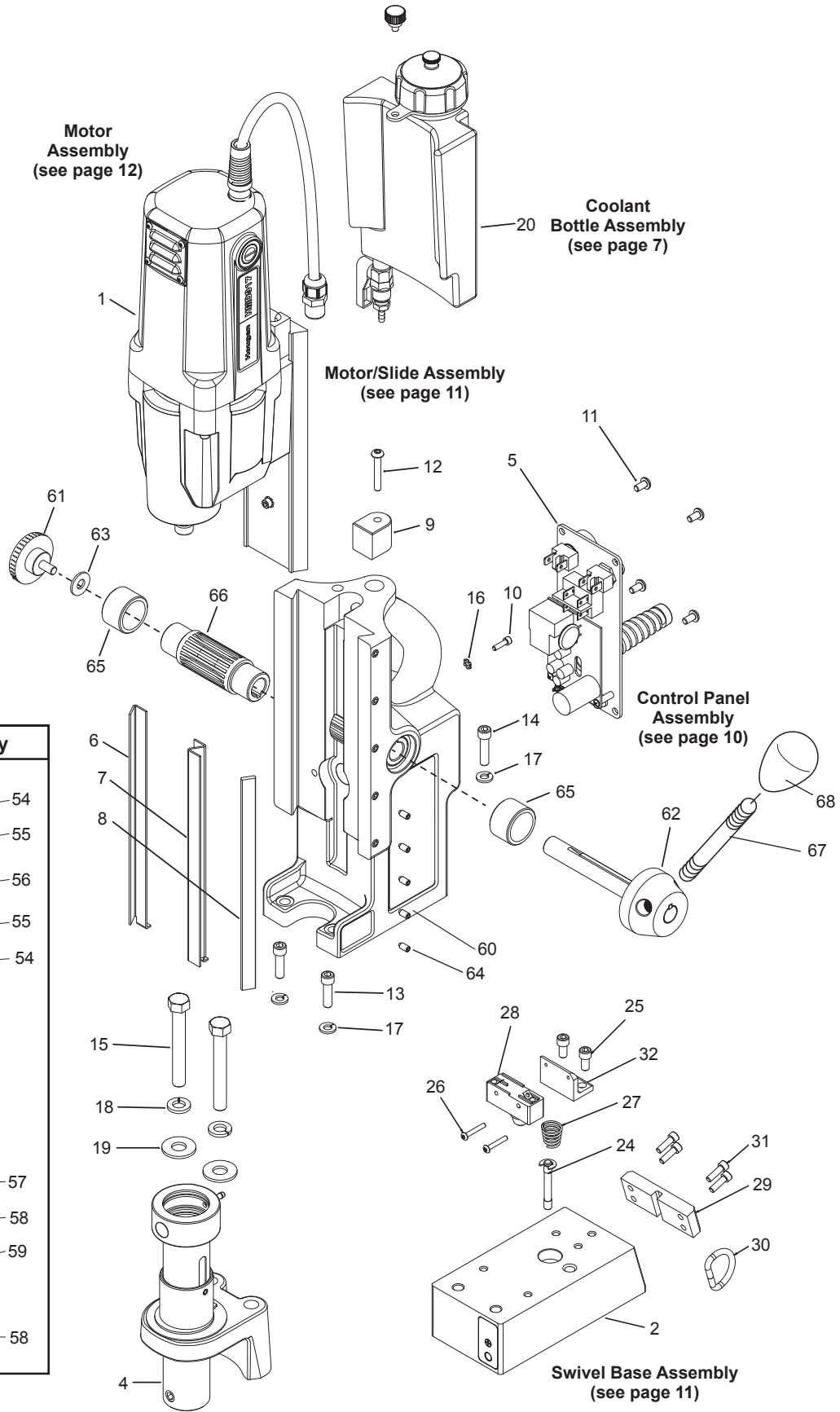
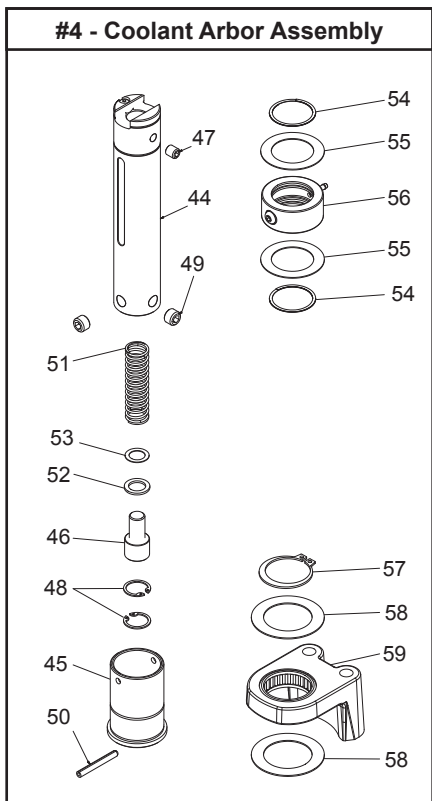



HMD917 Breakdowns			
Item	Part #	Description	Qty
1	08035	Motor / Slide Assy.	1
4	07917	Coolant Arbor Assy. Non Swivel	1
	08116	Coolant Arbor Assy. Swivel	1
5	08249	Control Panel	1
6	07834	Gib, Brass, Right Hand	1
7	07838	Gib, Brass, Left Hand	1
8	07842	Gib Steel	1
9	07833	Stop Block	1
10	17002	SCR SHC #6-32 x 1/2 LG	1
11	41044	SCR BHC #10-32 x 3/8 LG	4
12	10559	SCR BHC #10-32 x 1-1/4 LG	1
13	10553	SCR SHC 1/4-20 x 7/8 LG	2
14	40077	SCR SHC 1/4-20 x 1" LG	1
15	40594	Hex Bolt 3/8-24 x 3 (Non-Swivel)	2
	07088	Hex Bolt 3/8-24 x 2-1/4 (Non-Swivel)	2
16	90052	Lock Washer Ext. #6	1
17	90028	Lock Washer Helical 1/4	3
18	40391	Lock Washer Helical 3/8	2
19	40392	Washer Flat 3/8 Type A	2
20	07950	Coolant Bottle Assembly	1
Accessories Included			
	10565	Hex Key 1/8 wrench	1
	10730	Safety Chain 3/16 X 5' w/Snap Hook	1
	08080	Carrying Case w/Label	1
	24166	7/32" Hex Key for Arbor	1
	13013	5/32" Allen Wrench	1
67	10569	Feed Handle	3
68	04532	Knob - Oval	3

08041 Magnet Assembly			
Item	Part #	Description	Qty
2	08042	Magnet	1
24	04961	Plunger Assy.	1
25	10971	SCR SHC 1/4-20 x 1/2" LG	2
26	10972	SCR BHC #6-32 x 7/8" LG	2
27	17271	Spring - Taper, Comp.	1
28	04885	Microswitch Assy.	1
29	07887	Plate - Ring Retaining	1
30	24144	D-Ring	1
31	41046	SCR SHC #10-32 x 1/2" LG	4
32	04909	Bracket - Safety Switch	1

08116 Coolant Arbor Assembly			
Item	Part #	Description	Qty
44	07075	Arbor - Coolant	1
45	40223	Collar Ejector	1
46	07079	Spring Seat	1
47	40256	SCR Set 5/16-18 x 3/8 Oval Pt	1
48	10517	Ring - Retaining Internal	2
49	40222	SCR Set 7/16-14 x .305	2
50	40312	Pin-Roll 3/16 dia x 1.564 Altered	1
51	05049	Spring - Comp	1
52	07436	Washer - Rubber	1
53	07440	Washer - Shim 12 x 18 x .5mm	1
54	40302	Ring - Retaining	2
55	40301	Washer, Thrust 1-3/8 x 2-1/16 x 1/32	2
56	07445	Coolant Inducer	1
	40300	O-Ring ( <i>not shown</i> )	1
	07447	Fitting - Hose Barb Brass ( <i>not shown</i> )	1
	07082	SCR BHC 1/4-28 x 1/4 ( <i>not shown</i> )	1
57	40398	Ring - Retaining	1
58	40234	Washer, Thrust	2
59	07918	Front Support Bracket Assy.	1
	08117	Front Support Bracket Assy. - Swivel	1

07921 Housing Assembly			
Item	Part #	Description	Qty
60	07922	Drill Housing	1
61	05839	Knob - Comfort Rubber Grip	1
62	40254	Hub Assembly	1
63	10679	Washer - Flat 1/4 Type A	1
64	40237	Gib Screws	5
65	40231	Bushing - Bronze	2
66	40229	Feed Gear	1

# CONTROL PANEL BREAKDOWN & WIRING

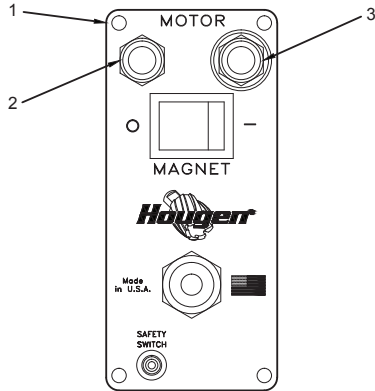

08249 Panel Assembly 08250 Panel Assembly - Type I			
Item	Part #	Description	Qty
1	07011	Faceplate	1
2	01335	Switch - Motor Off	1
3	01334	Switch - Motor On	1
6	01226	Guard Switch	1
7	04664	Magnet Switch	1
8	02548	Stand Off	3
9	07299	Power Cord Assembly	1
	08287	Power Cord Assembly - Type I	1
10	04879	Lens Clear L.E.D.	1
11	04878	Spacer L.E.D.	1
12	04881	Bulb L.E.D.	1
13	04877	Wire Harness L.E.D.	1
14	08673	Circuit Board	1
15	02547	SCR #4-40 x 5/16 LG	3
16	07522	Fuse	2

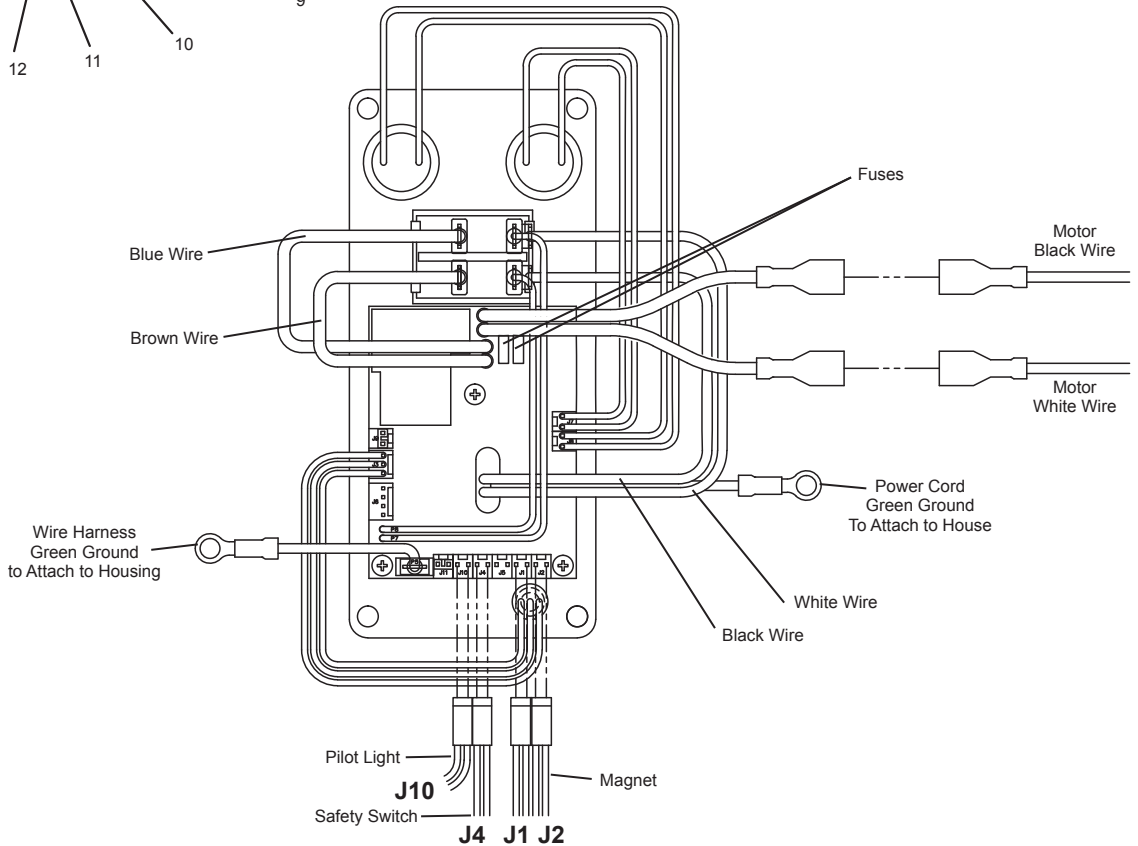
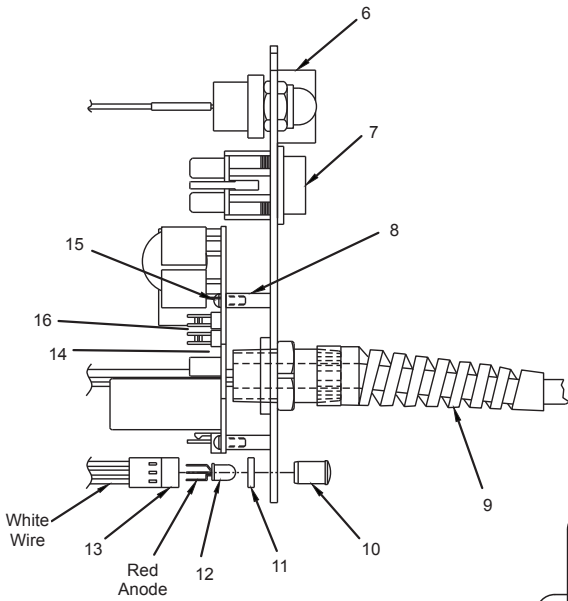

**MOTOR SLIDE ASSEMBLY BREAKDOWN**

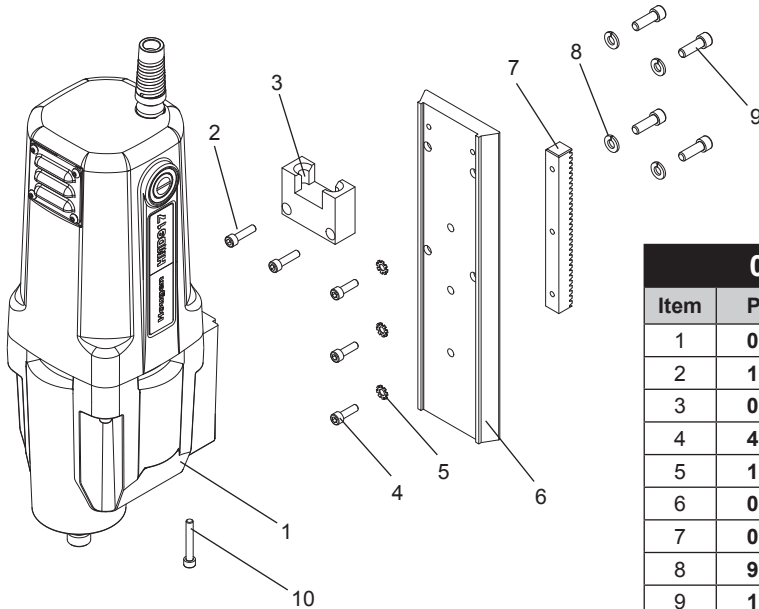

08035 Motor & Slide Assembly			
Item	Part #	Description	Qty
1	08036	Motor Complete Assembly	1
2	10649	SCR BHC #10-32 x 3/4	2
3	08063	Bottle Support	1
4	40038	SCR SHC #10-32 x 5/8 LG	3
5	10560	Lock Washer Ext. #10	3
6	07862	Slide - Dovetail	1
7	07934	Rack - Gear	1
8	90028	Lock Washer Helical 1/4	4
9	10624	SCR SHC 1/4-20 x 3/4	4
10	51044	SCR SHC 10-32 X 1-1/4	1

**SWIVEL BASE MAGNET ASSEMBLY BREAKDOWN**

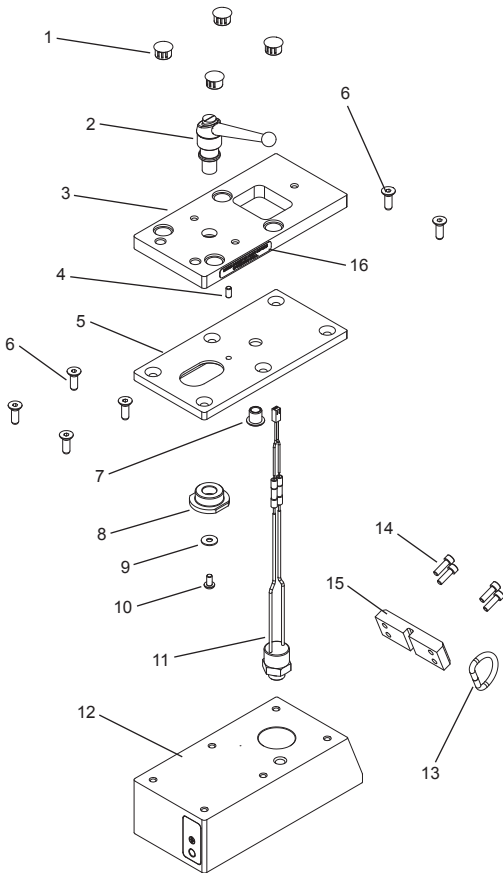

08109 Swivel Magnet Assembly			
Item	Part #	Description	Qty
1	07216	Plug Hole	4
2	05659	Clamp Handle Assembly	1
3	08096	Swivel Plate	1
4	02898	Dowel Pin	1
5	08097	Slide Plate	1
6	05743	SCR FHC 1/4-20 x 3/4 LG	6
7	07215	Bushing - Flange	1
8	05658	Pivot - Rod	1
9	90237	Washer - Flat #10	1
10	41044	SCR BHC #10-32 x 3/8 LG	1
11	05652	Ball Switch Assembly	1
12	08110	Magnet & Safety Switch Asm	1
	05975	Plunger (not shown)	1
13	24144	D - Ring	1
14	41046	SCR SHC #10-32 x 1/2" LG	4
15	07887	Plate - Retaining Ring	1
16	07230	Label - Swivel Warning	1

# MOTOR PARTS DIAGRAM

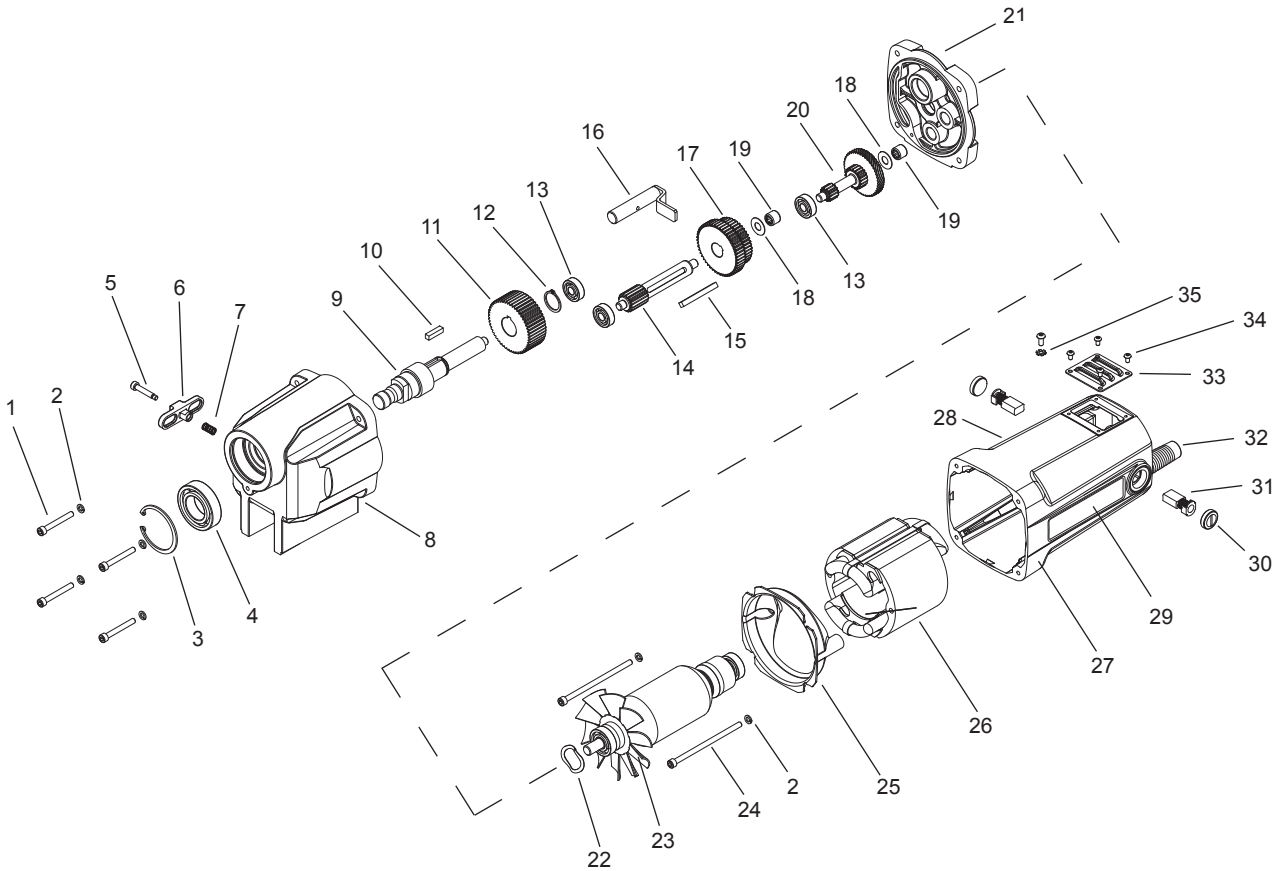

## 08036 Motor Assembly

Item	Part #	Description	Qty	Item	Part #	Description	Qty
1	41048	SCR-SHC #10-32 x 1-1/2	4	20	07911	Assembly Gears #2 & #3	1
2	50038	Washer - Lock Helical #10	6	21	07828	Gear Box Cover	1
3	07860	Retaining Ring	1	22	08070	Washer - Spring	1
4	40274	Bearing 25MM x 47MM x 12MM	1	23	08039	Armature Assembly	1
5	08069	SCR-SHSLD 3/16 x 7/8	1	24	07895	SCR-SHC #10-32 x 3-1/2 LG	2
6	07908	Switch	1	25	07892	Baffle	1
7	07910	Spring-Comp	1	26	08040	Field	1
8	07826	Gear Box Housing	1	27	07896	Motor Brush Holder Assembly	1
9	07901	Spindel - Motor Drive	1	28	08038	Motor Specs Label	1
10	07904	Key	1	29	07873	Motor Label	1
11	07900	Gear Spur Removable	1	30	24044	Brush Holder Cap	2
12	24160	Retaining Ring	1	31	24045	Carbon Brushes	2
13	24100	Ball Bearing	3	32	08338	Motor Cord	1
14	07899	Gear Spur Removable	1	33	07848	Cover, Brush Access	1
15	07905	Key	1	34	02385	SCR-BHC #6-32 x 1/4	4
16	07868	Shift Control Rod Arm	1	35	10538	Washer - Lock	1
17	07914	Assembly, Change gear	1				
18	17610	Washer - Flat 8mm	2				
19	07903	Needle Bearing	2				

## MAINTENANCE

In order to minimize wear on moving parts and to insure smoother operation and longer life for your magnetic drill, the following maintenance should be done periodically, based on use.

1. Regularly tighten all fasteners and replace all worn parts.
2. Check motor brushes and replace if worn.
3. Check power cord and cord from panel to motor and, if cracked or frayed, return to an authorized repair center for replacement.
4. Apply grease to the slide dovetails, brass gibs, and the feed gear rack. For best results use Shell Cyprina-RA or equivalent.
5. Remove arbor (see *arbor removal on page 14*) and pack the bearing in the front support bracket with grease. Use Shell Cyprina-RA or equivalent.
6. The safety switch plunger should be clean and lubricated with penetrating oil periodically. As necessary remove the magnet from drill and remove safety switch assembly from magnet. Push the plunger out of magnet. Clean out any debris from inside an around plunger hole in magnet. Coat the plunger with anti-seize. Replace plunger and safety switch assembly and tighten down screws. Replace magnet into drill housing.

## ADJUSTMENT OF GIBS

1. Check gibs regularly to make certain they are tight. Tighten as required.
2. Loosen all Gib Screws.
3. Feed the drill in and out a few times and then, with top of motor slide flush with top of housing, tighten the Gib Screws until you feel them touch the Steel Gib.
4. Feed the drill in and out again.
5. Adjust Gib Screws so that there is uniform pressure from top to bottom. (Top of motor slide flush with top of housing.)
6. Turn each Gib Screw in about 1/8 to 1/4 turn, depending upon your preference.
7. Gibs should be tight enough so that slide moves up and down smoothly with no wobble or shaking. (Looseness will cause cutter breakage.)

**NOTE: Gibs should be lubricated regularly.**

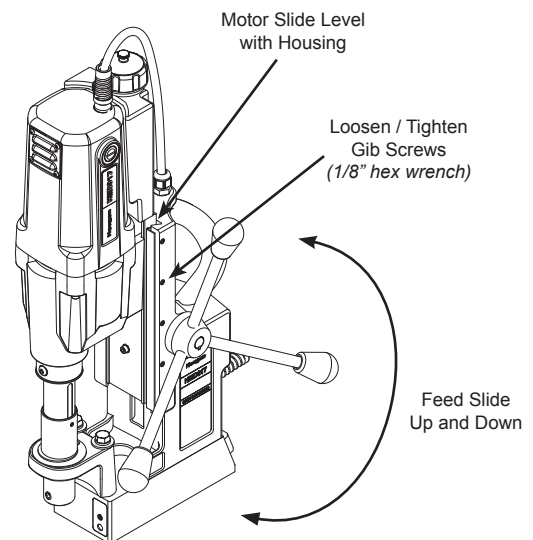

## ARBOR ADJUSTMENT

**Adjust Gibs before adjusting front support bracket.**

1. Arbor support bracket may become loose over time. Check Arbor Support bolts regularly to make certain they are tight. Tighten as required.
1. Loosen Arbor Support Bracket Bolts.
2. Be sure top of arbor is flush with the shoulder on motor output shaft. Also make certain arbor is securely fastened.
3. Turn feed handle until motor and spindle are at the bottom of their travel.
4. Tighten Arbor Support Bolts.
5. Feed slide up and down a few times, checking for free and uniform movement.

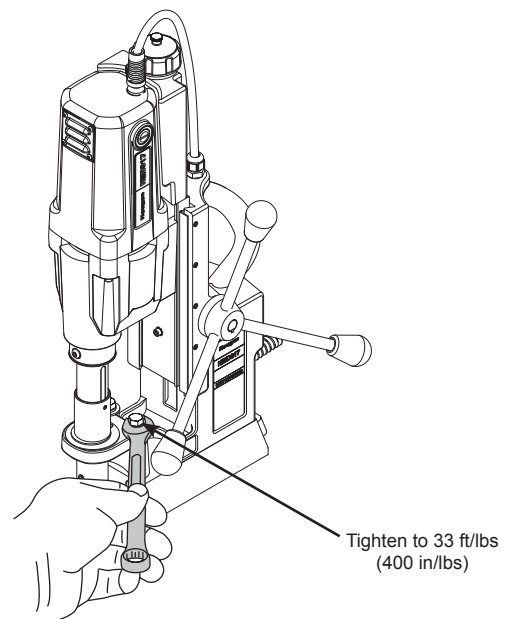

# ARBOR & FRONT SUPPORT BRACKET REMOVAL AND INSTALLATION

## Coolant Arbor

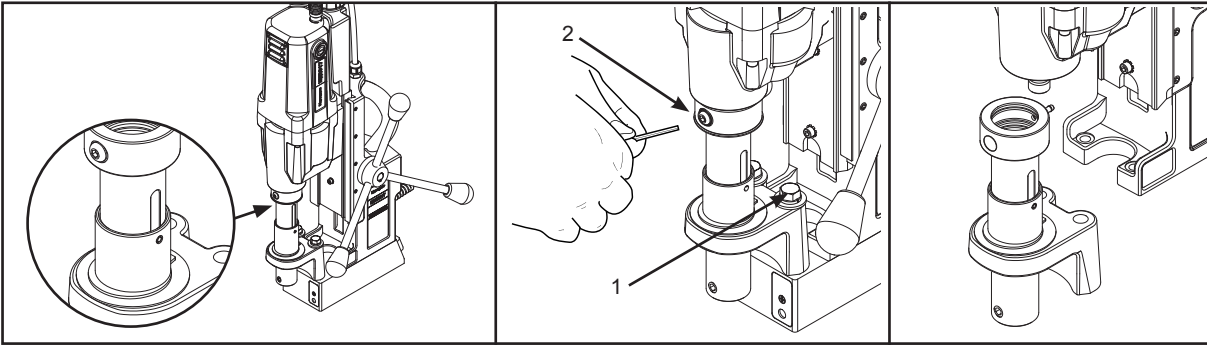

### Removal

1. Loosen arbor support bracket bolts.
2. Remove screw in coolant inducer. Rotate arbor until arbor screw is in line with hole.
3. Loosen set screw holding arbor onto motor output shaft.
4. Remove arbor.

### Installation

1. Hand tighten front support bracket bolts. Do not tighten all the way.
2. Slide arbor to full up position and hold arbor in position over hex drive motor output shaft.
3. Tighten set screw to hold arbor onto motor output shaft.
4. Replace coolant inducer screw.
5. Turn feed handle until motor and arbor are at the bottom of their travel.
6. Tighten front support bracket bolts to 400 in/lbs.
7. Run motor for 10 seconds. (If visual movement of arbor is noticed, restart at step 1)
8. Re-check for tightness of arbor set screws.

## SWIVEL BASE INSTRUCTIONS

The threads on the clamp handle assembly are a Left Handed thread meaning, turning clockwise would loosen the assembly and turning counter clockwise would tighten the assembly. The clamp handle is spring loaded, so you will need to lift & turn the entire clamp handle assembly when repositioning as if to be a ratchet drive.

### To Loosen the Swivel Plate Assembly

1. Lift the Clamp Handle Assembly, rotated counter-clockwise and release. This will reposition the lever for more movement.
2. With the Clamp Handle Assembly now down, pull the Clamp Handle Assembly clockwise. With this being a left handed thread, this will loosen the assembly.
3. If more travel is needed, lift the clamp handle assembly, rotate counter clockwise and release.
4. Pull the clamp handle assembly clockwise again. This amount of movement should be adequate to reposition the drill, more movement that this may cause the Magnet to disengage from the drill base.

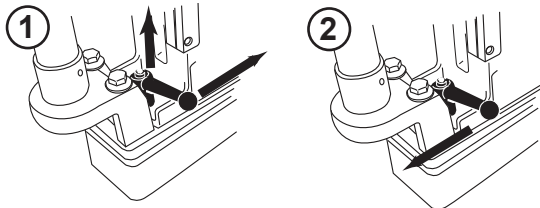

### To Tighten the Swivel Plate Assembly

1. Lift the Clamp Handle Assembly, rotated counter-clockwise and release. This will reposition the lever for more movement.
2. With the Clamp Handle Assembly now down, pull the Clamp Handle Assembly clockwise. With this being a left handed thread, this will loosen the assembly.
3. If more travel is needed, lift the clamp handle assembly, rotate counter clockwise and release.
4. Pull the clamp handle assembly clockwise again. This amount of movement should be adequate to reposition the drill, more movement that this may cause the Magnet to disengage from the drill base.

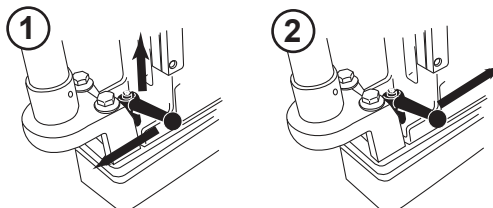

 **WARNING:** Clamp Handle **MUST BE TIGHT** prior to cutting holes  
Equipment damage or personal injury could occur

## HINTS FOR SMOOTHER OPERATION

1. Keep the inside of Hougén Cutter clear of chips. Chips will interfere with cutting to maximum depth, maybe impede the free oil flow and can cause cutter breakage.
2. Keep work, machine, arbor and Hougén Cutter free of chips and dirt.
3. Tighten all bolts and fasteners regularly.
4. We highly recommend using a light viscosity cutting fluid (preferably Hougén Cutting Fluid).
5. Occasionally check metering of cutting fluid flow. Lack of cutting fluid may cause Hougén Cutter to freeze in cut, slug to stick and may result in poor cutter life.
6. Always start cut with light feed pressure and then increase sufficiently to achieve maximum cutting rate.
7. Ease off on pressure as cutter begins to break through at the end of the cut.
8. Keep slide dovetails, brass gibs and feed rack lubricated and free of chips and dirt.
9. When slug hangs up in cutter, turn off motor and bring cutter down on a flat surface. This will normally straighten a cocked slug, allowing it to be ejected.
10. When cutting large diameter or deep holes it may be necessary to stop in the middle of the cut to add cutting fluid and remove the chips from around the arbor. (When doing this **DO NOT** raise the cutter out of the hole. Doing so can allow chips to get under the teeth of the cutter. This will make it difficult to restart the cut.)

**#1 cause of cutter breakage and prematurely dull teeth is too little feed pressure**

**"Babying" the cutter through the cut will only decrease tool life.**

## REMEDIES FOR HOLEMAKING PROBLEMS

- 1. Trouble: Magnetic base won't hold effectively to work.**
    - a. Cause: Chips or dirt under magnet.  
Remedy: Clear area of chips and dirt.
    - b. Cause: Irregular surface on bottom of magnet or on workpiece.  
Remedy: Lightly surface grind the bottom of the magnet flat and/or file imperfections flat on the work surface as needed.
  - 2. Trouble: Cutter tends to move across surface of work.**
    - a. Cause: Magnetic base not holding effectively.  
Remedy: See causes and remedies under No. 1 above.
    - b. Cause: Too much feed pressure at start of cut.  
Remedy: Use light pressure until a groove is cut. The groove then serves as a stabilizer.
    - c. Cause: Worn pilot.  
Remedy: Replace pilot
    - d. Cause: Worn cutter.  
Remedy: Replace or have cutter resharpened.
  - 3. Trouble: Out of round holes.**
    - a. Cause: Worn arbor support bracket bearing and or ejector collar.  
Remedy: Replace: (only a few thousandths wear permissible.)
    - b. Cause: Misaligned support bracket  
Remedy: Realign support bracket
    - c. Cause: Misaligned or loose arbor set screw.  
Remedy: Tighten set screw.
  - 4. Trouble: Motor and slide won't stay in set position**
    - a. Cause: Gibs too loose  
Remedy: Adjust gibs
  - 5. Trouble: Erratic or intermittent feed.**
    - a. Cause: Worn or pinion and/or rack.  
Remedy: Replace worn parts.
  - 6. Trouble: Motor doesn't run when motor START button is pushed.**
    - a. Cause: Magnet is not turned on  
Remedy: Push magnet ON button.
    - b. Cause: Magnet on rough or dirty work surface and safety switch not fully depressed.  
Remedy: File work surface flat and clean all chips and oil from under magnet.
    - c. Cause: No power  
Remedy: Check power source and extension cords.
    - e. Cause: Worn motor brushes  
Remedy: Replace brushes
    - f. Cause: Faulty motor START switch  
Remedy: Return unit to an authorized repair center to have switch replaced.
- NOTE: If you are unable to correct any malfunction after trying the above, do not attempt to operate the drill. Return the unit to the factory or authorized repair center for service.**

## COMMERCIAL / INDUSTRIAL LIMITED WARRANTY

Hougen Manufacturing, Incorporated warrants its Portable Magnetic Drills and its Electro-hydraulic Hole Punchers for a period of 1 year and other products for ninety (90) days from date of purchase against defects due to faulty material or workmanship and will repair or replace (at its option) without charge any items returned. This warranty is void if the item has been damaged by accident or unreasonable use, neglect, improper service, or other causes not arising out of defects in material or workmanship. No other expressed warranty is given or authorized. Hougen Manufacturing, Inc. disclaims any implied warranty of MERCHANTABILITY or FITNESS for any period beyond the expressed warranty and shall not be liable for incidental or consequential damages. Some states do not allow exclusions of incidental or consequential damages or limitation on how long an implied warranty lasts and, if the law of such a state governs your purchase, the above exclusion and limitation may not apply to you. This warranty gives you specific legal rights and you may also have other rights which vary from state to state.

To obtain warranty service: return the item(s), transportation prepaid, to your nearest Factory Authorized Warranty Repair Center or to Hougen Manufacturing, Inc., 3001 Hougen Drive, Swartz Creek, Michigan 48473.

Hougen Drills are warranted against manufacturing defects only. Subject to Hougen Manufacturing inspection.

THIS WARRANTY IS IN LIEU OF ANY OTHER WARRANTY, EXPRESSED OR IMPLIED, INCLUDING ANY WARRANTY OF MERCHANTABILITY OR FITNESS FOR A PARTICULAR PURPOSE.

© 2017 Hougen Manufacturing, Inc.

*Photographs and Specifications shown are accurate in detail at time of printing. Manufacturer reserves the right to make improvements and modifications without prior notice. Hougen, Rotabroach, and Hougen-Edge are proprietary trademarks of Hougen Manufacturing Inc.*

## HOUGEN AUTHORIZED WARRANTY REPAIR CENTERS

Hougen Authorized Warranty Repair Centers have been factory trained to properly service and repair Hougen Portable Magnetics Drills. To locate an Authorized Warranty Repair Centers near you, please visit:

[www.hougen.com](http://www.hougen.com)



**Hougen Manufacturing, Inc.**

P.O. Box 2005 • Flint, MI 48501-2005  
3001 Hougen Drive • Swartz Creek, MI 48473  
Phone (810) 635-7111 • Fax (810) 635-8277  
[www.hougen.com](http://www.hougen.com) • [info@hougen.com](mailto:info@hougen.com)

© 2017 Hougen Manufacturing, Inc.

