

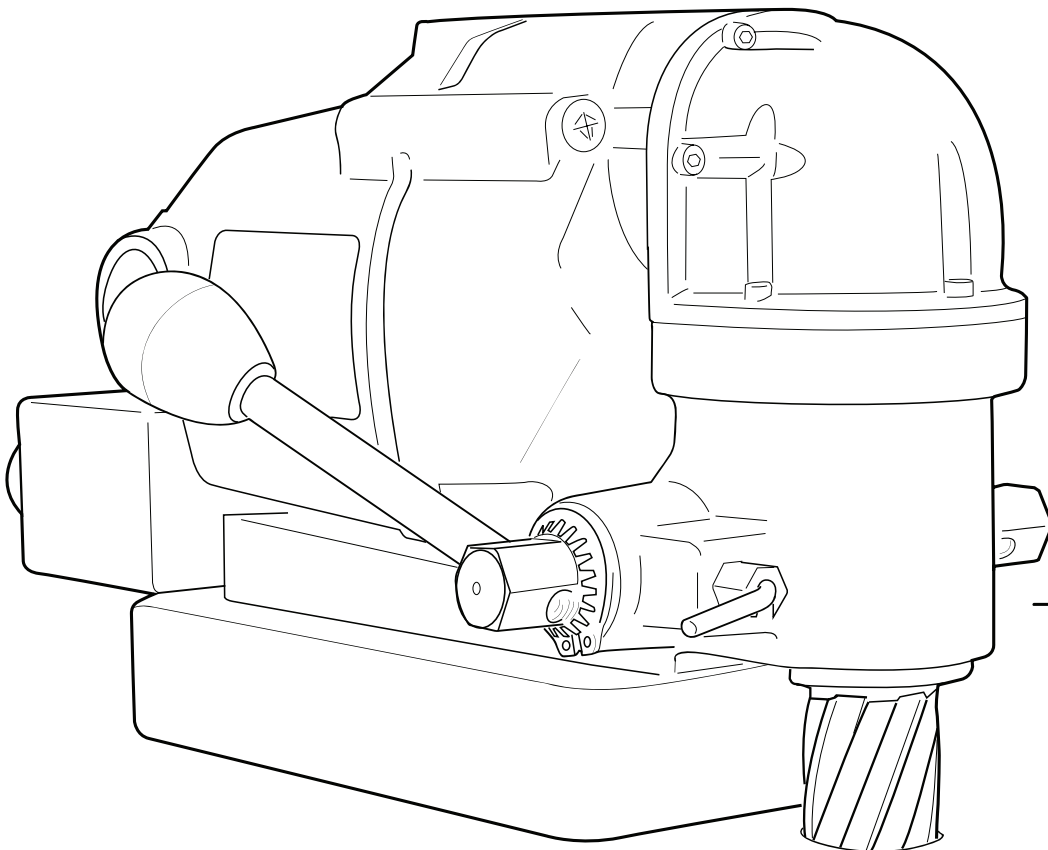

# HMD115 SERIES PORTABLE MAGNETIC DRILLS

## OPERATOR'S MANUAL

COVERS DRILL MODEL 0115201, 0115301 & 0115401



**FOR USE WITH ROTALOC<sup>™</sup> CUTTERS**

# HOUGEN® PORTABLE MAGNETIC DRILL

## Welcome to Hougen

Congratulations on your purchase of the Hougen® Portable Magnetic Drill. Your model is designed to produce superior holes quickly and efficiently. Through constant innovation and development, Hougen is committed to provide you with hole-producing tools and products to help you be more productive.

Before attempting to operate your new Portable Magnetic Drill, please read all instructions first. These include the Operator's Manual and Warning Label on the unit itself. With proper use, care, and maintenance, your model will provide you with years of effective hole drilling performance. Once again, thank you for selecting our product and welcome to Hougen.

Your new Hougen Magnet Base Drill now incorporates a Label for the Drill Part Number and Serial Number. Below gives an explanation of the Part Number and the location of the Label is shown on the Drill Breakdown Diagram .

**The Ultra Low Profile Drill is offered in many versions. Refer to the Serial/Part number Label on your housing to direct you to the correct breakdown.**

### Specifications

Cutter Type.....RotaLoc  
 Hole Capacity.....1/2" to 1-1/16" (12mm - 27mm)  
 Depth of Cut.....3/4" (19mm)  
 Motor.....230 volt, 3.6A450 RPM  
 Electrical System.....230 volt, 50/60 Hz, 8A, 960W  
 Net Weight.....21.3 Lb

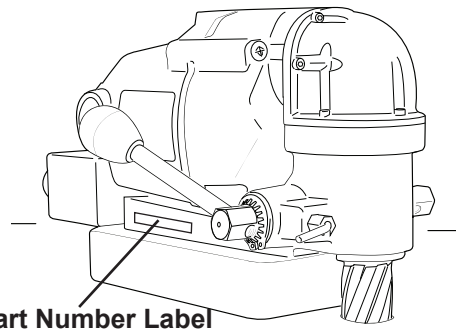

## INDEX

Important Safety Instructions	3-4	HMD115 Parts Breakdown	8
Review of Controls	5	Parts List & Rotaloc™ Cutters	9
Rotaloc™ Cutter Installation	5	Motor Diagram & Parts List	10
Operating Instructions	6	Commercial Limited Warranty	12
Wiring & Hookup Diagram	7	Factory Authorized Warranty Centers	12

## SAFETY FIRST

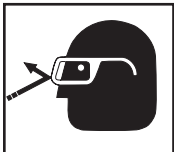

Always wear eye protection while using cutting tools, or in the vicinity of cutting.



**CAUTION!** Cutters are sharp. Wear gloves when installing or removing cutter from arbor. Do not grab a rotating cutter.

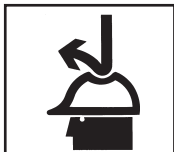

**CAUTION!** The slug is ejected at the end of the cut. Do not aim cutter or arbor so that ejected slug may hit someone around, or below you.



**CAUTION!** To prevent electric shock, do not use power tools near wet areas, or where power tool may become wet.

# Important Safety Instructions



**WARNING:** Read and understand all instructions. Failure to follow all instructions listed below, may result in electrical shock, fire and/or serious personal injury.

## Work Area

**Keep your work area clean and well lit.** Cluttered benches and dark areas invite accidents.

**Do not operate power tools in explosive atmospheres, such as in the presence of flammable liquids, gases or dust.** Power tools create sparks which may ignite the dust or fumes.

**Keep bystanders, children, and visitors away while operating a power tool.** Distractions can cause you to lose control.

## Electrical Safety

**Grounded tools must be plugged into an outlet properly installed and grounded in accordance with all codes and ordinances. Never remove the ground prong or modify the plug in any way. Do not use any adapter plugs. Check with a qualified electrician if you are in doubt as to whether the outlet is properly grounded.** If the tools should electrically malfunction or break-down, grounding provides a low resistance path to carry electricity away from the user.

**Avoid body contact with grounded surfaces such as pipes, radiators, ranges and refrigerators.** There is an increased risk of electric shock if your body is grounded.

**Don't expose power tools to rain or wet conditions.** Water entering a power tool will increase the risk of electric shock.

**Do not abuse the cord. Never use the cord to carry the tools or pull the plug from an outlet. Keep cord away from heat, oil, sharp edges or moving parts. Replace damaged cords immediately.** Damaged cords increase the risk of electric shock.

**When operating a power tool outside, use an outdoor extension cord marked "W-A" or "W";** These cords are rated for outdoor use and reduce the risk of electrical shock.

## Personal Safety

**Stay alert, watch what you are doing and use common sense when using a power tool. Do not use tool while tired or under the influence of drugs, alcohol, or medication.** A moment of inattention while operating power tools may result in serious personal injury.

**Dress properly. Do not wear loose clothing or jewelry. Contain long hair. Keep your hair, clothing, and gloves away from moving parts.** Loose clothes, jewelry, or long hair can be caught in moving parts.

**Avoid accidental starting. Be sure switch is off before plugging in.** Carrying tools with your finger on the switch or plugging in tools that have the switch on invites accidents.

**Remove adjusting keys or switches before turning the tool on.** A wrench or a key that is left attached to a rotating part of the tool may result in personal injury.

**Do not overreach. Keep proper footing and balance at all times.** Proper footing and balance enables better control of the tool in unexpected situations.

**Use safety equipment. Always wear eye protection.** Dust mask, non-skid safety shoes, hard hat, or hearing protection must be used for appropriate conditions.

**Always use safety strap.** Mounting can release.

## Tool Use and Care

**Use clamps or other practical way to secure and support the work piece to a stable platform.** Holding the work by hand or against your body is unstable and may lead to loss of control.

**Do not force tool. Use the correct tool for your application.** The correct tool will do the job better and safer at the rate for which it is designed.

**Do not use tool if switch does not turn it on or off.** Any tool that cannot be controlled with the switch is dangerous and must be repaired.

**Disconnect the plug from the power source before making any adjustments, changing accessories, or storing the tool.** Such preventive safety measures reduce the risk of starting the tool accidentally.

**Store idle tools out of reach of children and other untrained persons.** Tools are dangerous in the hands of untrained users.

**Maintain tools with care. Keep cutting tools sharp and clean.** Properly maintained tools, with sharp cutting edges are less likely to bind and are easier to control.

**Check for misalignment or binding of moving parts, breakage of parts, and any other condition that may affect the tools operation. If damaged, have the tool serviced before using.** Many accidents are caused by poorly maintained tools.

**Use only accessories that are recommended by the manufacturer for your model.** Accessories that may be suitable for one tool, may become hazardous when used on another tool.

## Service

**Tool service must be performed only by qualified repair personnel.** Service or maintenance performed by unqualified personnel could result in a risk of injury.

**When servicing a tool, use only identical replacement parts. Follow instructions in the Maintenance section of this manual.** Use of unauthorized parts or failure to follow Maintenance Instructions may create a risk of electric shock or injury.

# Important Safety Instructions - Continued



**WARNING:** Read and understand all instructions. Failure to follow all instructions listed below, may result in electrical shock, fire and/or serious personal injury.

## Safe Electrical Connection

Your Mag Drill is rated for use on 115VAC or 230V at 50-60Hz. Do not attempt to use drill on power sources rated other than this.

## Plugs and Receptacles

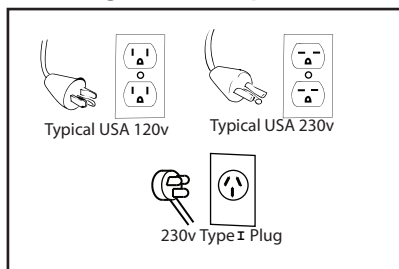

Wet electrical connections are shock hazards. To prevent the cutting fluid from traveling along the cord and contacting the plug or power outlet, tie a drip loop as shown. Also elevate extension cords or gang box connections.

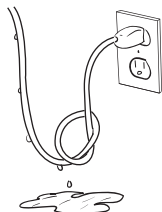

## Extension Cords

Use only 3-wire extension cords that have 3-prong grounding type plugs and 3-pole receptacles that accept the tool's plug. Replace or repair damaged cords. Make sure the conductor size is large enough to prevent excessive voltage drop which will cause loss of power and possible motor damage.

## Extension Cord Table

LENGTH OF CORD, FEET	RECOMMENDED WIRE GAUGE	RECOMMENDED WIRE GAUGE
	115V MOTOR 10 - 12 AMPS	230 V MOTOR 5 - 6 AMPS
UP TO 25	16	18
26 - 50	14	18
51 - 100	10	16
101 - 200	8	14
201 - 300	6	12
301 - 500	4	10

## Outdoor Use Extension Cords

When tool is used outdoors, use only extension cords intended for use outdoors and so marked.

## Additional Safety Precautions

Arbor and cutter should never be used as a hand-hold. Keep hands and clothing away from all moving parts. Do not use Houghen Cutters where ejected slug might cause injury (slug ejected at end of cut). Also, adhere to all operating instructions. Do not drill through any surface that may contain live electrical wiring. Drilling into a live wire could cause exposed metal parts of the drill to be made live. Remove chips wrapped around Cutter and arbor after each hole. With motor off and power disconnected, grasp chips with leather gloved hand or pliers and pull while rotating counterclockwise. Should the cutter become jammed in the work, stop the unit immediately to prevent personal injury. Disconnect the drill from the power supply and loosen jammed cutter by turning the arbor counterclockwise. Never attempt to free the jammed cutter by starting the motor. Service at authorized repair center only. product warranty.

## Operating Near Welding Equipment

DO NOT operate this unit on the same work surface that welding is being performed on. Severe damage to the unit, particularly the power cord, could occur. This could also result in personal injury to the operator.

## Circuit Breaker (If Applicable)

Changing of the circuit breaker to a higher amp rated breaker, or bypassing the circuit breaker is not recommended and will void

## Circuit Breaker Operation (If Applicable)

The circuit breaker is a thermal breaker. When it reaches the higher temperature rating it will trip and cause the unit to shut down. This is a protective device and can be reset after 5 to 10. To reset the breaker, press the breaker button back in. If it does not reset, let the unit cool a little longer until you can push the button in and it stays in position.

**Save these Instructions.**

## REVIEW OF CONTROLS

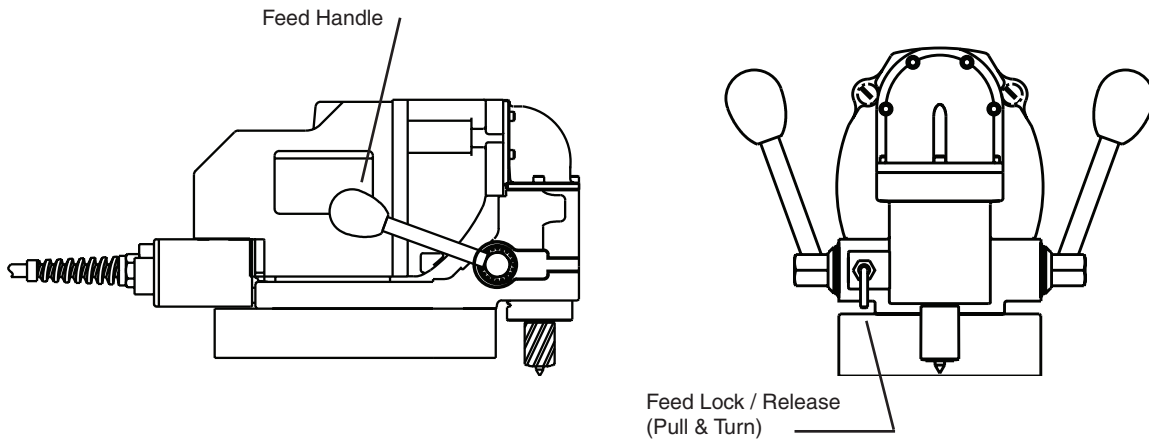
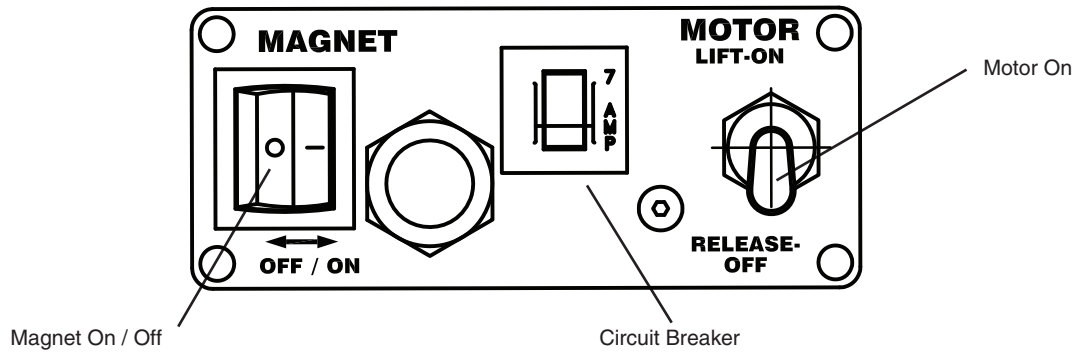

## ROTALOC™ CUTTER INSTALLATION

1. Disconnect machine from power source.
2. Insert pilot into cutter.
3. Align flat on shank with pin in spindle.
4. Insert cutter into spindle.
5. Give cutter 1/4 turn in opposite direction of flutes.

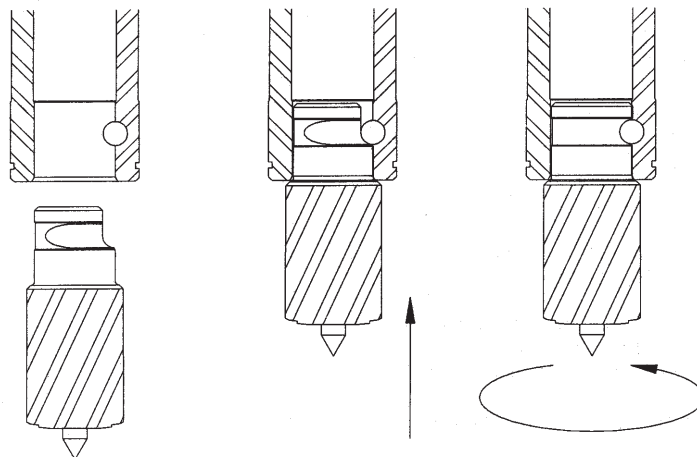

# OPERATING INSTRUCTIONS

1. Place drill on material and locate for drilling hole.
2. Press magnet switch to "ON"
3. Thread safety strap through opening between motor and drill housing. Ensure that strap does not interfere with operation of feed handles. Insert tab of strap into buckle. Cinch strap tight to material and drill housing. Check for slack and adjust as needed.

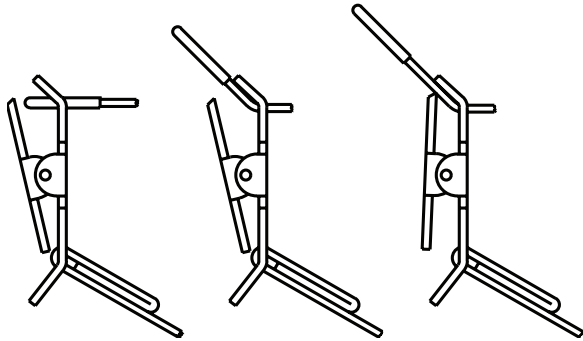

## CAUTION:

- Keep strap clear of cutting area, chips, and rough edges on material.
- Inspect strap periodically for fraying and damage. Do not use a damaged safety strap.

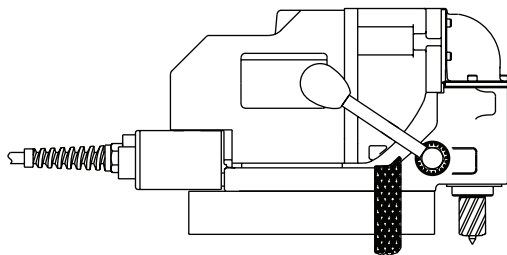

4. Apply liberal amount of cutting fluid or stick lubricant to cutter. Additional lubrication may be needed to complete cut.
5. Disengage feed lock/release.
6. Press and hold motor switch. (Note: Switch must be held in "ON" position while cutting)
7. Feed Cutter slowly into workpiece. Only after cutting path is established to a depth of about 1/16" can additional force be applied to feed handles. Ease up on feed pressure as cutter starts breaking through.

**CAUTION:** Do not over-feed cutter. Excessive feed pressure may cause the magnet to break free from material.

## DRILLING MULTIPLE LAYER MATERIALS:

Second layer penetration may be difficult. Slight additional feed pressure may be required (avoid over-feed as noted above).

If unable to penetrate second layer, withdraw cutter from material ejecting slug and clean away any remaining chips. Feed cutter in hole and continue cut.

- Release motor switch when cut is finished.
- Fully retract cutter from material, ejecting the slug.
- Engage feed lock/release.
- Remove safety strap.

8. Turn magnet switch to "OFF" position.

**CAUTION:** Retain firm hold on drill to prevent dropping.

Cutter I.D. may collect chips, restricting depth of cut. Cutter should be frequently inspected and any chips or debris removed.

## OPTIONAL FEED METHODS:

- 5/8" Box Wrench
- Ratchet with 5/8" Socket (shown below)
- NO PLIERS OR OPEN END WRENCH (will damage threaded feed handle mounting holes)

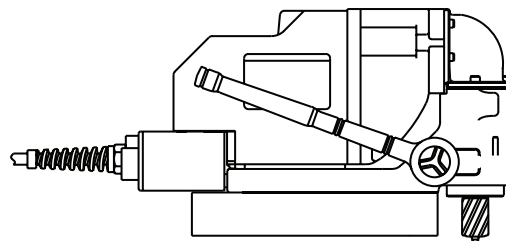

**17553 230V CONTROL PANEL ASSEMBLY**  
**17577 230V CONTROL PANEL ASSEMBLY TYPE I PLUG**

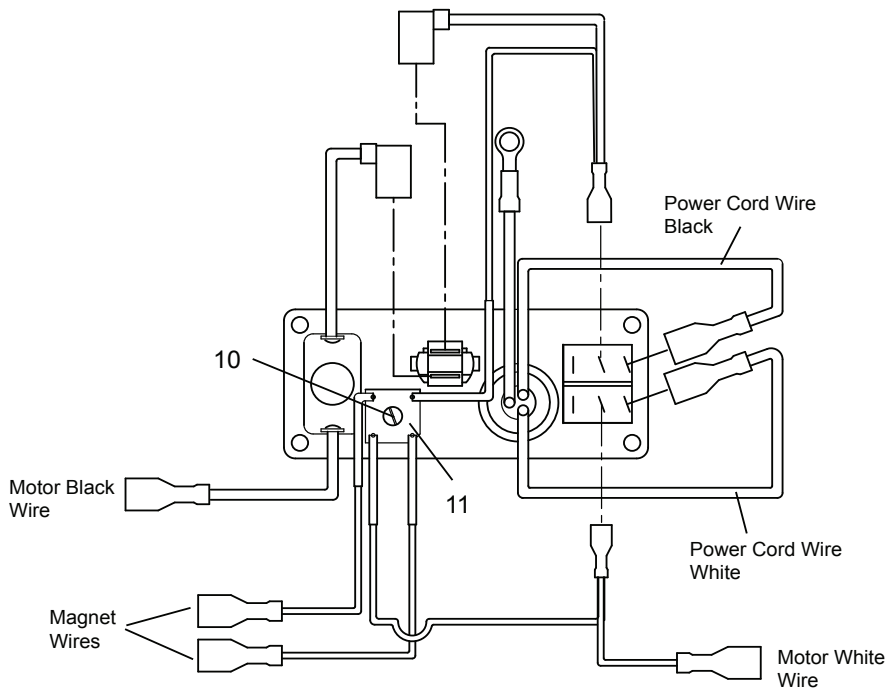
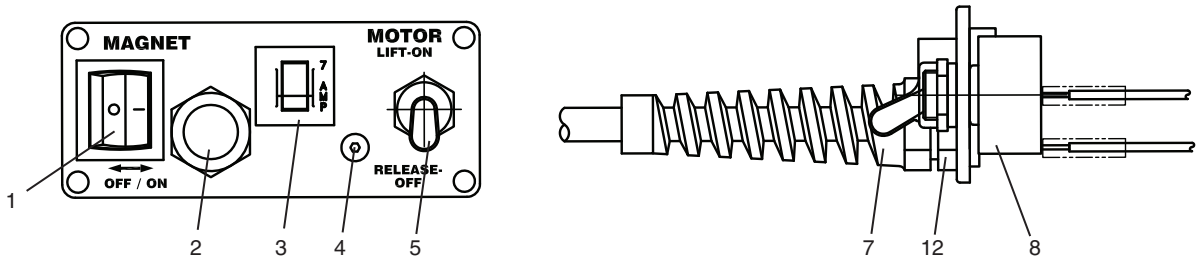

The 17577 is assembled with a Type I plug.

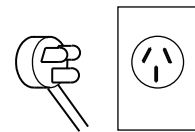

Item	Part #	Description	Qty.	Item	Part #	Description	Qty.
1	04437	Rocker Switch (230V) note1	1	7	17552	Power Cord Assembly (230V)	1
2	17575	Cover w/label (230V)	1		04449	Power Cord Assembly (230V) Type I Plug	1
3	04438	Circuit Breaker 3amp (230V)	1	8	08053	Momentary Switch Assembly	1
4	17032	SCR-BHC 6-32 X 1/2	1	10	01835	Nylon Nut	1
5	08054	Switch Seal	1	11	17048	Rectifier Assembly	1
				12	17041	Knurled Nut	1

Note 1- an alternative 04437 maybe used that is not a lighted switch.

0115201 HMD115, LOW PROFILE, 230V  
 0115301 HMD115, LOW PROFILE, 230V TYPE I PLUG  
 0115401 HMD115, LOW PROFILE, 230V, NO PLUG

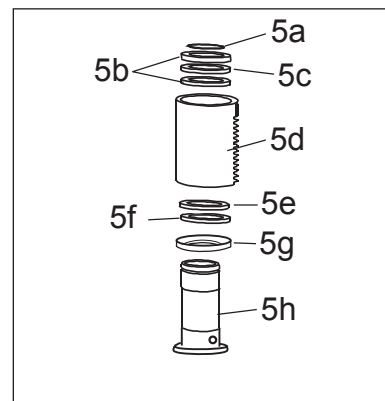
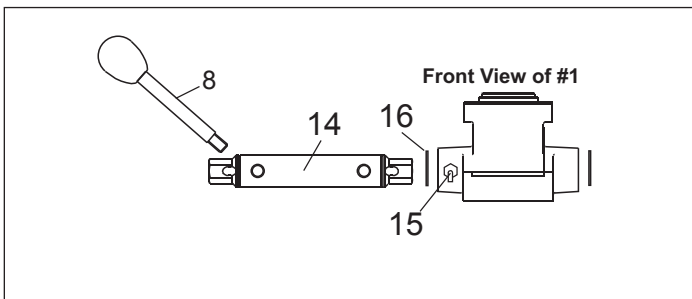
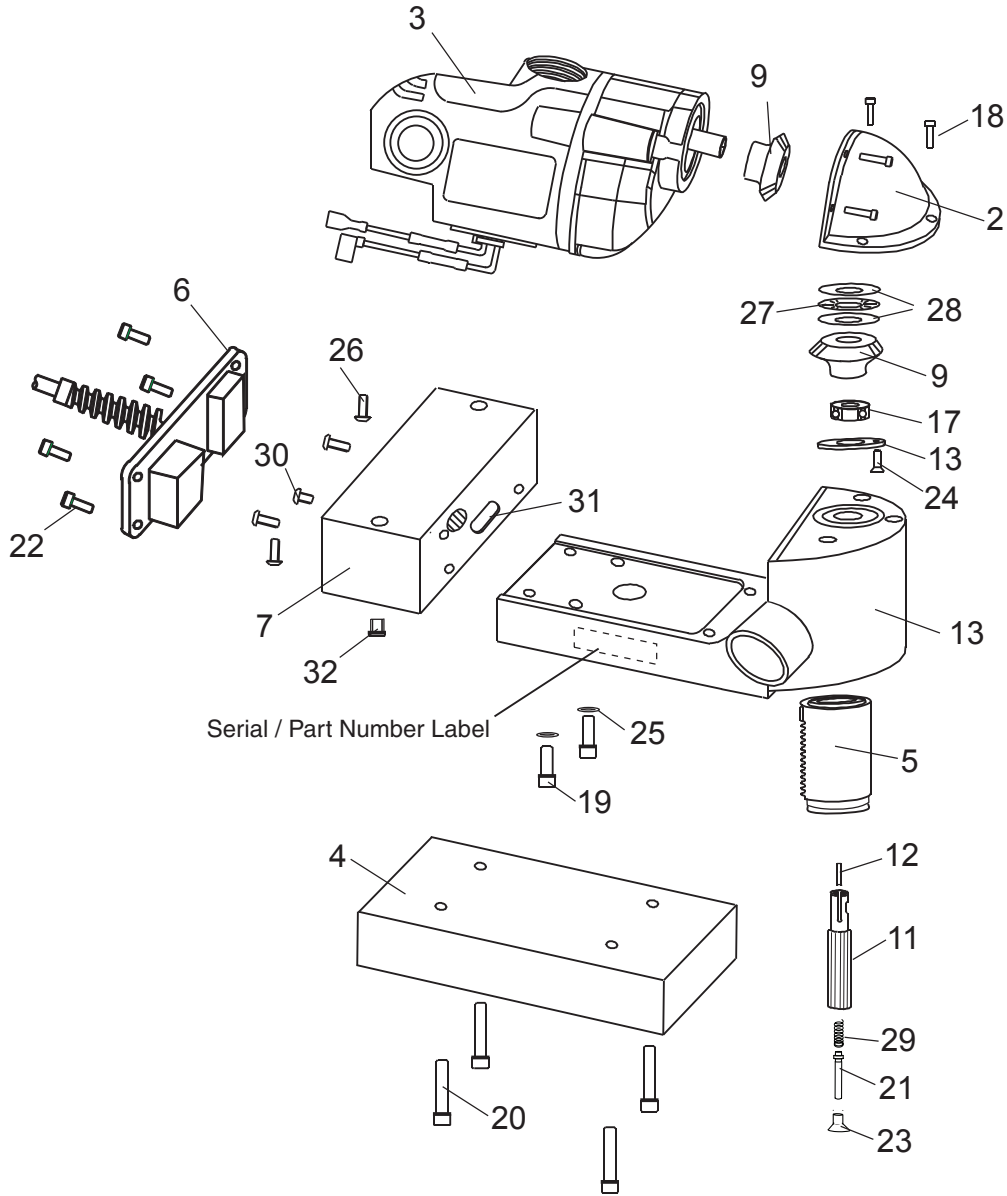



<b>HMD115 Parts List</b>			
<b>Item</b>	<b>Qty</b>	<b>Part No.</b>	<b>Description</b>
1	1	<b>17525</b>	Blue Housing
2	1	<b>17510</b>	Gear Cap Assembly
3	1	<b>07175</b>	<b>230V</b> Motor Assembly
4	1	<b>17574</b>	<b>230V</b> Magnet Assembly
5	1	<b>17594</b>	Arbor / Quill Assembly (includes 5a-5h)
5a	1	<b>04720</b>	Retaining Ring
5b	2	<b>17547</b>	Steel Thrust Washer
5c	1	<b>17546</b>	Bronze Thrust Washer
5d	1	<b>17595</b>	Quill Assembly
5e	1	<b>17644</b>	Thrust Washer (1 I.D x 1.56 O.D)
5f	1	<b>17645</b>	Thrust Bearing (1 I.D x 1.56 O.D)
5g	1	<b>17643</b>	Steel Seal
5h	1	<b>17597</b>	Arbor Assembly
6	1	<b>17553</b>	<b>230V</b> Control Panel Assembly (0115201 & 0115401) note 1
	1	<b>17577</b>	<b>230V</b> Control Panel Assembly. (115301)
7	1	<b>17042</b>	Electrical Box
8	2	<b>17588</b>	Feed Handle Assembly
9	2	<b>17534</b>	Miter Gear Set
11	1	<b>17501</b>	Splined Shaft
12	1	<b>17513</b>	3/32 sq. X 9/16 lg.
13	1	<b>17509</b>	Bearing Retainer
14	1	<b>17022</b>	Feed Gear
15	1	<b>17039</b>	Spring Plunger
16	2	<b>17023</b>	Retaining Ring
17	1	<b>17010</b>	Ball Bearing
18	7	<b>17002</b>	SHC Screw #6-32 X 1/2
19	2	<b>75096</b>	SHC Screw M6 X 1 X 20mm
20	4	<b>40108</b>	SHC Screw 1/4-20 X 1-1/4
21	1	<b>17494</b>	Plunger
22	4	<b>41042</b>	BHC Screw #8-32 X 3/8
23	1	<b>17493</b>	FHC Screw Modified
24	3	<b>04409</b>	FHC Phillips #6-32 X 1/2
25	2	<b>50035</b>	Lock Washer
26	4	<b>75094</b>	SHS Screw M5 X .8 X 12mm
27	1	<b>17516</b>	Roller Thrust Bearing
28	2	<b>17517</b>	Thrust Washer
29	1	<b>17492</b>	Spring
30	1	<b>04439</b>	Screw #10-32 X 3/16
31	1	<b>04573</b>	Seal
32	2	<b>17543</b>	Tapered Plug

## Rotaloc™ Cutters for HMD115

The Rotaloc™ Annular cutters are made specifically for the HMD115. They are equipped with 5/8" tool-less bayonet style twist and lock shank, and can drill up to 3/4" deep in single or stacked plate. They are made of premium high speed steel and available in diameters from 1/2" to 1-1/16".

<b>Part #</b>	<b>Diameter</b>	<b>Part #</b>	<b>Diameter</b>
Use Pilot 17100 or 17101		Use Pilot 17100 or 17101	
<b>17116</b>	1/2"	<b>17300</b>	12mm
<b>17118</b>	9/16"	<b>17302</b>	13mm
<b>17120</b>	5/8"	<b>17304</b>	14mm
<b>17122</b>	11/16"	<b>17306</b>	15mm
<b>17124</b>	3/4"	<b>17308</b>	16mm
<b>17126</b>	13/16"	<b>17310</b>	17mm
<b>17128</b>	7/8"	<b>17312</b>	18mm
<b>17130</b>	15/16"	<b>17314</b>	19mm
<b>17132</b>	1"	<b>17316</b>	20mm
<b>17134</b>	1-1/16"	<b>17318</b>	21mm
		<b>17320</b>	22mm
		<b>17322</b>	23mm
		<b>17324</b>	24mm
		<b>17325</b>	24.5mm
		<b>17326</b>	25mm
		<b>17328</b>	26mm
		<b>17330</b>	27mm

**Note 1-** Replacement assembly will have a standard U.S.A 230 volt power cord plug.

# 07175 230V MOTOR DIAGRAM & PARTS LIST

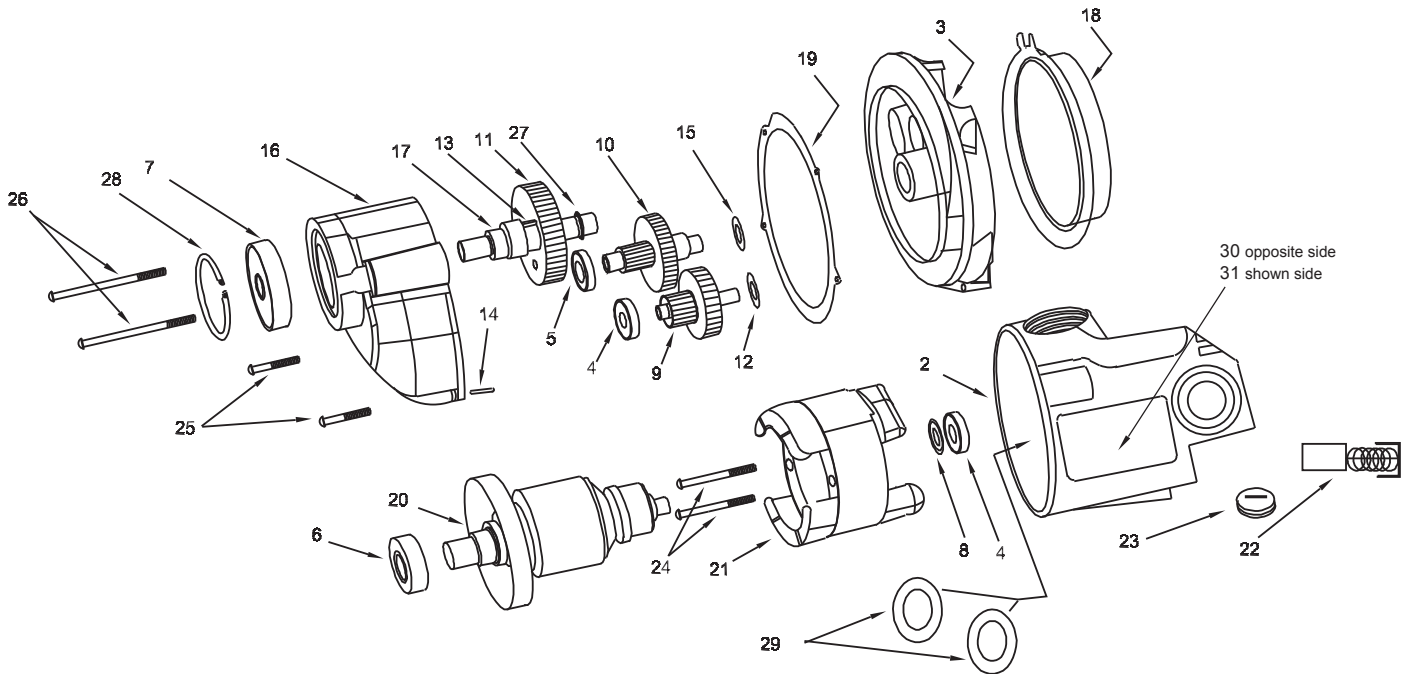

Item #	Part #	Description	Qty	Item #	Part #	Description	Qty
1	17523	Motor Assembly (230V)	1	17	17616	Spindle	1
2	17600	Field case	1	18	17617	Fan Guide	1
3	17601	Gear Housing Cover	1	19	17618	Gasket	1
4	17602	Ball Bearing	2	20	17631	Armature (230V)	1
5	17603	Ball Bearing	1	21	17629	Field (230V)	1
6	17604	Ball Bearing	1	22	05519	Carbon Brush (230V)	2
7	17605	Ball Bearing	1	23	17622	Brush Cap	2
8	17606	Dust Seal	1	24	17623	Pan Head Screw (Field)	2
9	17607	1st Inter. Gear Assy	1	25	17624	Pan Head Screw (Short)	2
10	17608	2nd Inter. Gear Assy	1	26	17625	Pan Head Screw (Long)	2
11	17609	Spur Gear	1	27	17626	Retaining Ring	1
12	17610	Flat Washer	1	28	17627	Retaining Ring	1
13	17611	Key	1	29	17632	Paper Washer	2
14	17612	Dowel Pin	1	30	07152	Label - Motor (230V)	1
15	17613	Flat Washer	1	31	17537	Safety Label (230V)	1
16	17615	Gear Housing (incldes 7 & 28)	1				

## NOTES

## COMMERCIAL / INDUSTRIAL LIMITED WARRANTY

Hougen Manufacturing, Incorporated warrants its Portable Magnetic Drills and its Electro-hydraulic Hole Punchers for a period of 1 year and other products for ninety (90) days from date of purchase against defects due to faulty material or workmanship and will repair or replace (at its option) without charge any items returned. This warranty is void if the item has been damaged by accident or unreasonable use, neglect, improper service, or other causes not arising out of defects in material or workmanship. No other expressed warranty is given or authorized. Hougen Manufacturing, Inc. disclaims any implied warranty of MERCHANTABILITY or FITNESS for any period beyond the expressed warranty and shall not be liable for incidental or consequential damages. Some states do not allow exclusions of incidental or consequential damages or limitation on how long an implied warranty lasts and, if the law of such a state governs your purchase, the above exclusion and limitation may not apply to you. This warranty gives you specific legal rights and you may also have other rights which vary from state to state.

To obtain warranty service: return the item(s), transportation prepaid, to your nearest Factory Authorized Warranty Repair Center or to Hougen Manufacturing, Inc., 3001 Hougen Drive, Swartz Creek, Michigan 48473.

Hougen Drills are warranted against manufacturing defects only. Subject to Hougen Manufacturing inspection.

THIS WARRANTY IS IN LIEU OF ANY OTHER WARRANTY, EXPRESSED OR IMPLIED, INCLUDING ANY WARRANTY OF MERCHANTABILITY OR FITNESS FOR A PARTICULAR PURPOSE.

© 2014 Hougen Manufacturing, Inc.

*Photographs and Specifications shown are accurate in detail at time of printing. Manufacturer reserves the right to make improvements and modifications without prior notice. Hougen, Rotabroach, and Hougen-Edge are proprietary trademarks of Hougen Manufacturing Inc.*

## HOUGEN AUTHORIZED WARRANTY REPAIR CENTERS

Hougen Authorized Warranty Repair Centers have been factory trained to properly service and repair Hougen Portable Magnetics Drills. To locate an Authorized Warranty Repair Centers near you, please visit:

[www.hougen.com](http://www.hougen.com)

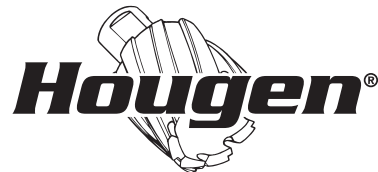

**Hougen Manufacturing, Inc.**

P.O. Box 2005 • Flint, MI 48501-2005  
3001 Hougen Drive • Swartz Creek, MI 48473  
Phone (810) 635-7111 • Fax (810) 635-8277  
[www.hougen.com](http://www.hougen.com) • [info@hougen.com](mailto:info@hougen.com)

© 2014 Hougen Manufacturing, Inc.

