

CONTROL PANEL /HOOKUP DIAGRAM

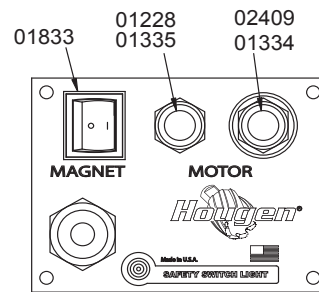

PART #	DESCRIPTION	QTY	PART #	DESCRIPTION	QTY
01226	Switch Guard	1	04879	Clear Lens	1
01228	Red Switch Cover	1	04881	Bulb	1
01334	Motor ON Switch	1	05208	Green Ground Wire Assy.	1
01335	Motor OFF Switch	1	05826	Circuit Board	1
01833	Rocker Switch	1	05828	Faceplate	1
02409	Green Switch Cover	1	05911	Faceplate Assy	1
04877	Wire Harness	1	17490	Power Cord Assy	1
04878	Spacer	1			

HMD150 DRILL PARTS DIAGRAM

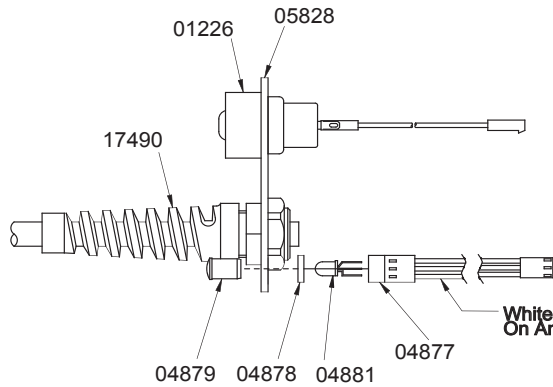
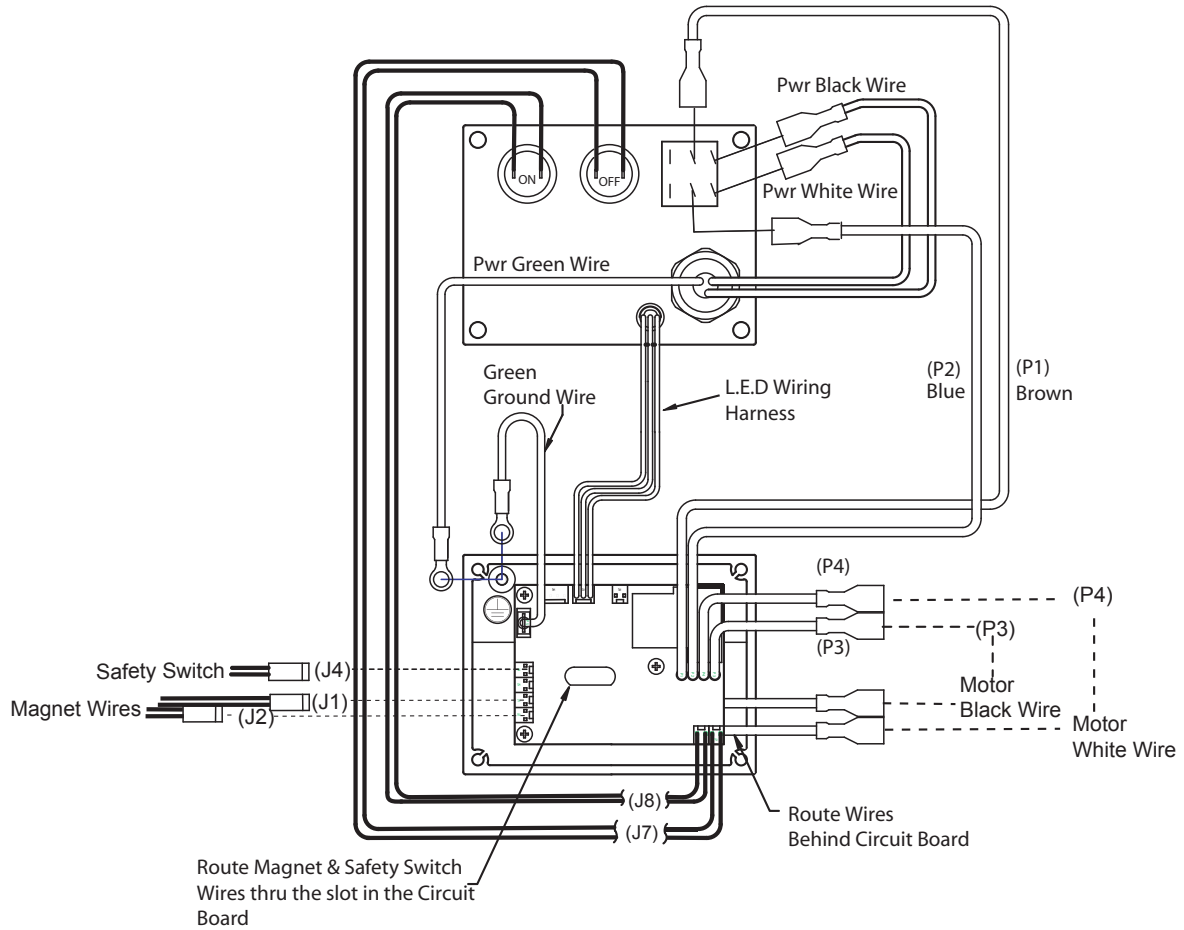
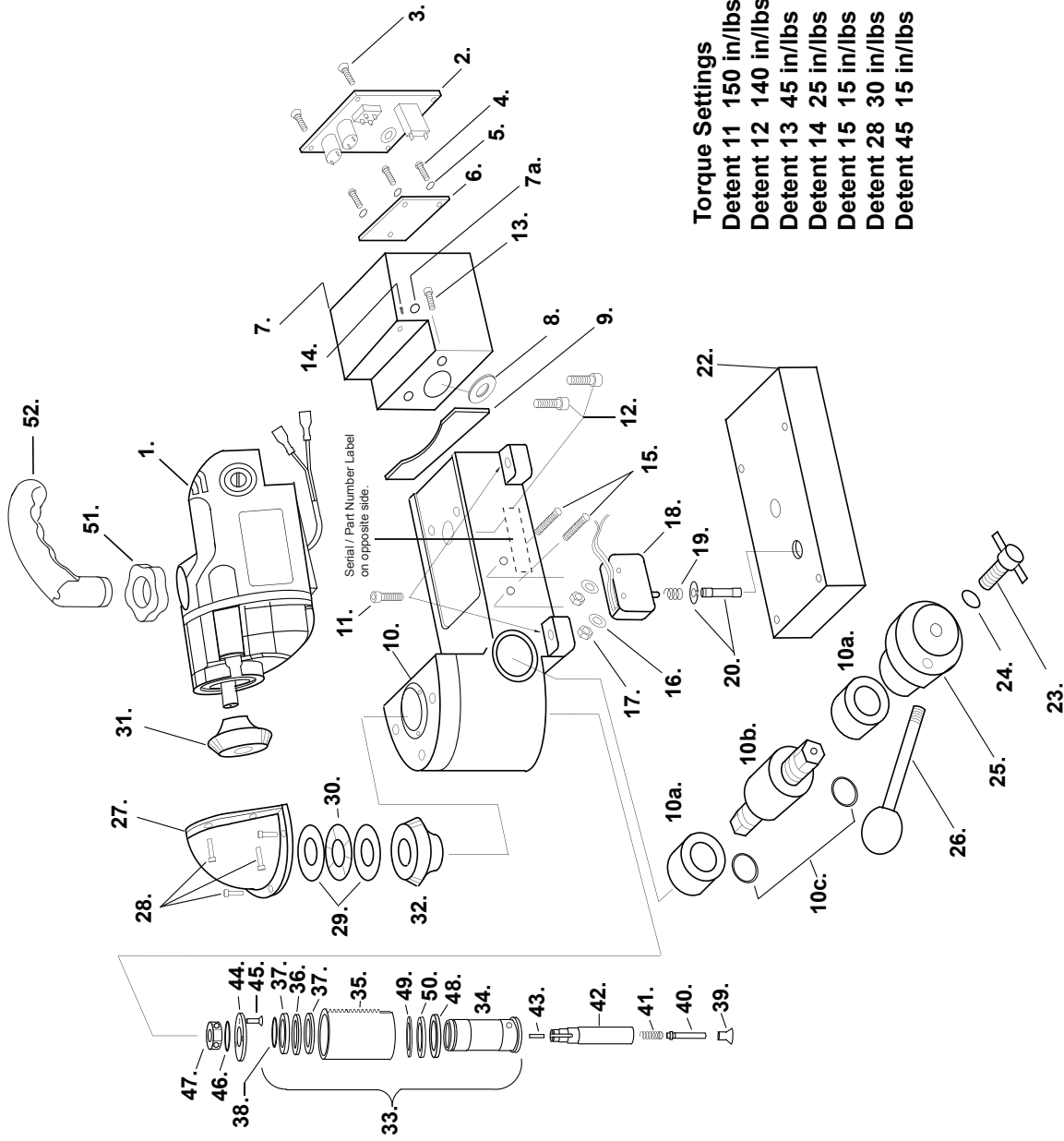

Torque Settings

Detent 11	150 in/lbs
Detent 12	140 in/lbs
Detent 13	45 in/lbs
Detent 14	25 in/lbs
Detent 15	15 in/lbs
Detent 28	30 in/lbs
Detent 45	15 in/lbs

HMD150 PARTS LIST

Item #	Part #	Description	Qty	Item#	Part #	Description	Qty
1	07124	Motor Assy	1	26	17283	Feed Handle Assy	1
2	05911	Faceplate Assy.	1	27	17510	Gear Cap Assy	1
3	24081	Screw Self Tapping	4	28	17002	SCR SHC #6-32	7
4	02547	Phillips Screw	3	29	17517	Thrust Washer	2
5	10714	Washer Lock #4	3	30	17516	Thrust Bearing	1
6	05826	Circuit Board	1	31	17502	Gear Left Hand	1
7	17691	Electrical Box	1	32	17278	Gear Right Hand	1
7a	17557	Ground Label	1	33	17646	Quill & Arbor Assy	1
8	17274	Grommet	1	34	17649	Arbor Assy	1
9	17293	Motor Seal	1	35	17647	Quill Assy	1
10	17279	Housing Assy	1	36	17546	Washer Thrust Bronze	1
10a	17495	Bronze Bearing	2	37	17547	Washer Thrust Steel	2
10b	17298	Feed Gear	1	38	04720	Retaing Ring Lt Hand	1
10c	40546	O Ring	2	39	17493	SCR Flat Head Mod.	1
11	10553	SCR SHC 1/4-20	4	40	17494	Plunger	1
12	75096	SCR SHC M6 x 20mm	2	41	17492	Comp. Spring	1
13	75094	SCR SHC M5 x 12mm	2	42	17280	Splined Shaft	1
14	04439	SCR BHS #10-32	1	43	17277	Key 1/8" Square	1
15	17476	SCR BHC Safety Torx	2	44	17289	Washer Brg. Ret	1
16	90052	Washer Lock #6	2	45	04718	SCR-Pan Phillips	3
17	40374	Nut Hex #6-32	2	46	17475	Retaining Ring	1
18	04885	Safety Switch	1	47	17270	Ball Bearing	1
19	17271	Taper Spring	1	48	17643	Shield, Thrust Washer	1
20	17285	Plunger Assy	1	49	17644	Thrust Washer	1
22	17651	Magnet	1	50	17645	Thrust Needle Bearing	1
23	17291	SCR SHC M6-1	1	51	05920	Locking Nut 1"-14	1
24	90027	1/4" Flat Washer	1	52	05921	Handle	1
25	17282	Feed Hub Assy	1				

Motor Diagram and Parts List

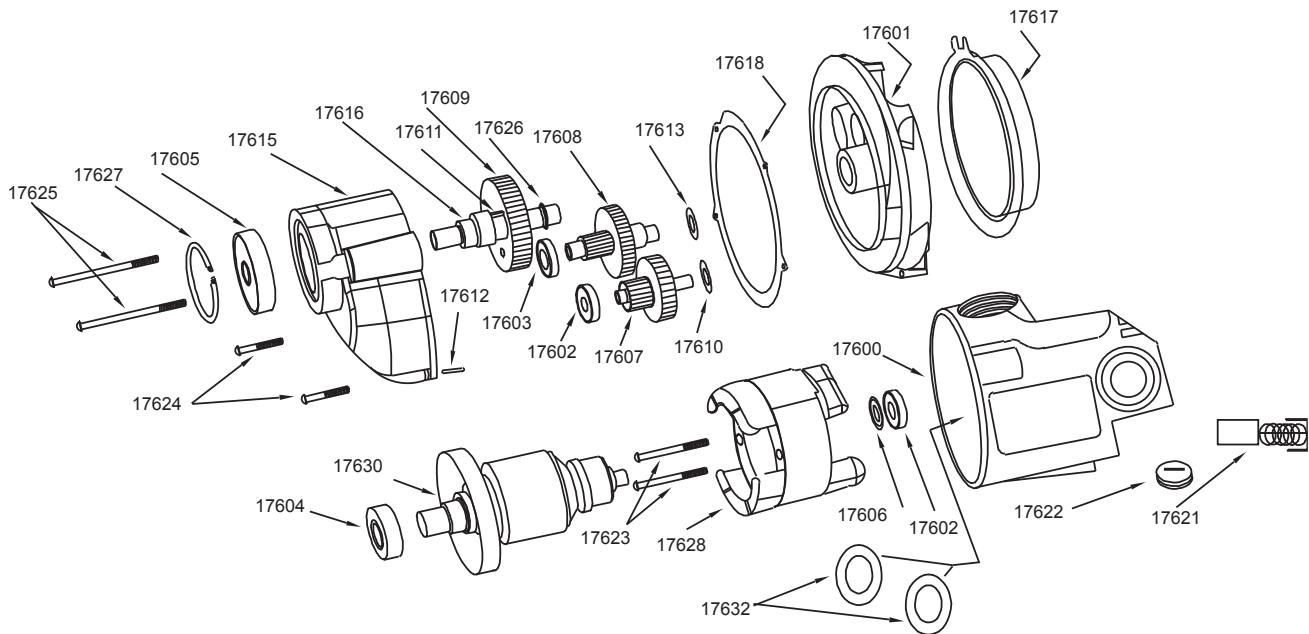

Part #	Description	Qty	Part #	Description	Qty
04502	Brush Cover	1	17612	Dowel Pin	1
10538	Washer #8	1	17613	Flat Washer	1
11053	Screw BHS #8-32	1	17615	Gear Housing	1
17276	Motor Assy	1	17616	Spindle	1
17294	Label, Motor Specs	1	17617	Fan Guide	1
07025	Label, Motor Safety	1	17618	Gasket	1
17600	Field Case	1	17630	Armature	1
17601	Gear Housing	1	17628	Field	1
17602	Ball Bearing	2	17621	Carbon Brush	2
17603	Ball Bearing	1	17622	Brush Cap	2
17604	Ball Bearing	1	17623	Pan Head Screw	2
17605	Ball Bearing	1	17624	Pan Head Screw Short	2
17606	Dust Seal	1	17625	Pan Head Screw Long	2
17607	1st Inter. Gear Assy	1	17626	Retaining Ring	1
17608	2nd Inter. Gear Assy	1	17627	Retaining Ring	1
17609	Spur Gear	1	17632	Paper Washer	2
17610	Flat Washer	1	75289	Pan Head Screw	2
17611	Key	1			