

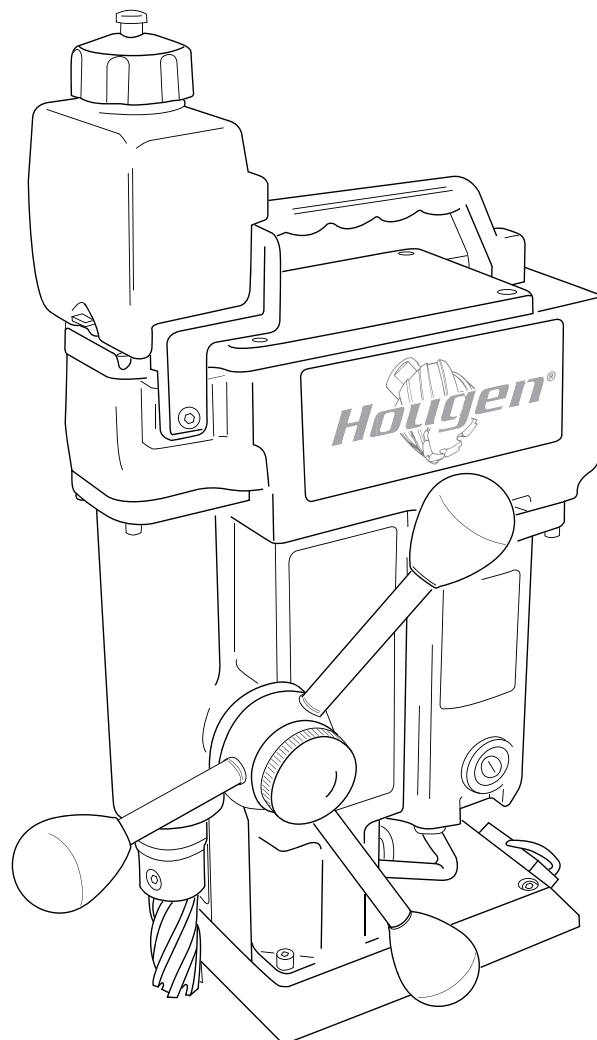

HMD505

PORTABLE MAGNETIC DRILL

OPERATOR'S MANUAL



FOR USE WITH HOUGEN "12,000-SERIES" CUTTERS

HOUGEN® Portable Magnetic Drill

Model HMD505

Welcome to Hougen

Congratulations on your purchase of the Hougen® Portable Magnetic Drill Model HMD501. Your model is designed to produce superior holes quickly and efficiently. Through constant innovation and development, Hougen is committed to provide you with hole-producing tools and products to help you be more productive.

Before attempting to operate your new Portable Magnetic Drill, please read all instructions first. These include the Operator's Manual and Warning Label on the unit itself. With proper use, care, and maintenance, your model will provide you with years of effective hole drilling performance. Once again, thank you for selecting our product and welcome to Hougen.

Your new Hougen Magnet Base Drill now incorporates a Label for the Drill Part Number and Serial Number. Below gives an explanation of the Part Number and the location of the Label is shown on the Drill Breakdown Diagram.

Part No.	Description
0505102	HMD505, 2 speed with coolant, 115 volt

Specifications

Cutter Type.....	"12,000-Series"
Hole Capacity.....	7/16" to 2-3/8"
Depth of Cut.....	3"
Motor.....	250/450 RPM, 14A
Net Weight.....	45 lbs.

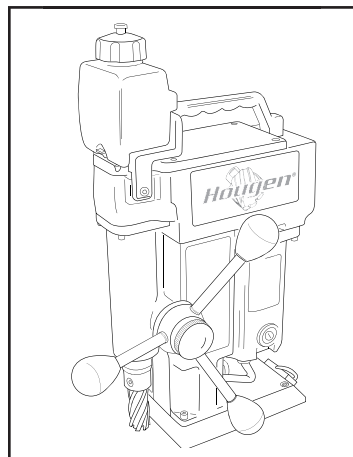

INDEX

Important Safety Instructions	3-4	Optional Pressurized Coolant, Arbor Assembly	9
Unpacking Drill, Cutter Installation	5	Panel Layout	10
Installation of cutting fluid bottle	6	Panel Hookup Diagram	11
Operation of cutting fluid bottle	6	Exploded View	12
Magnet Operation, Operating instructions	6	Drill Parts List	13
Hints for smoother operation, Maintenance	7	"12,000-Series" Hougen Cutters	14
Motor Assy.,	8	Commercial / Industrial Limited Warranty	15

SAFETY FIRST

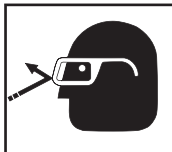

Always wear eye protection while using cutting tools, or in the vicinity of cutting.



CAUTION! Cutters are sharp. Wear gloves when installing or removing cutter from arbor. Do not grab a rotating cutter.



CAUTION! The slug is ejected at the end of the cut. Do not aim cutter or arbor so that ejected slug may hit someone around, or below you.



CAUTION! To prevent electric shock, do not use power tools near wet areas, or where power tool may become wet.

IMPORTANT SAFETY INSTRUCTIONS



WARNING: When using electric tools, basic safety precautions should always be followed to reduce the risk of fire, electric shock, and personal injury, including the following:

- 1. Read All Instructions**
- 2. Grounding Instructions**

This tool should be grounded while in use to protect the operator from electric shock. The tool is equipped with a 3-conductor cord and a 3-prong grounding type plug to fit the proper grounding type receptacle. The green (or green and yellow) conductor in the cord is the grounding wire. Never connect the green (or green and yellow) wire to a live terminal. If your unit is for use on 115V, it has a plug that looks like that shown in sketch (A). If it is for use on 230V, it has a plug that looks like that shown in sketch (B). An adapter, see sketch and (C), is available for connecting sketch (A) type plugs to 2-prong receptacles. The green-colored rigid ear, lug, or the like, extending from the adapter must be connected to a permanent ground, such as a properly grounded outlet box. No adapter is available for a plug as shown in sketch (D).

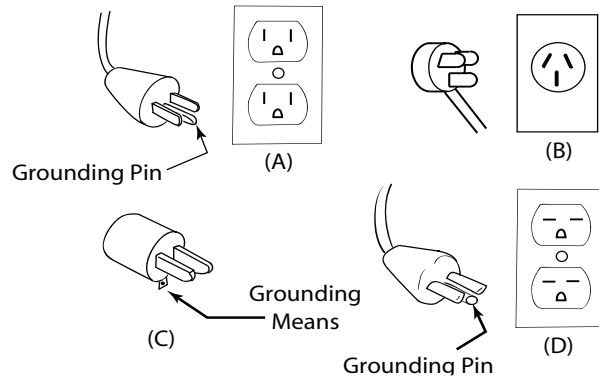

- 3. Extension Cords**

Use only 3-wire extension cords that have 3-prong grounding type plugs and 3-pole receptacles that accept the tool's plug. Replace or repair damaged cords.

Make sure the conductor size is large enough to prevent excessive voltage drop which will cause loss of power and possible motor damage. See Table below.

Length of Cord, Feet	Recommended Wire Gauge	Recommended Wire Gauge
	115V Motor 10-14 Amps	230V Motor 4-7 Amps
Up to 25	16	18
26-50	14	18
51-100	10	16
101-200	8	14
201-300	6	12
301-500	4	10

- 4. Do Not Force Tool**

It will do the job better and faster at the rate for which it was intended.

- 5. Keep Work Area Clean**

Cluttered areas and benches invite injuries. Keep dirt and chips from under magnet and Hougén Cutter area.

- 6. Consider Work Area Environment**

Do not expose tool to rain.

Do not use tool in damp or wet locations.

Keep work area well lit.

Do not use tool in presence of flammable liquids or gases.

- 7. Guard Against Electric Shock**

Prevent body contact with grounded surfaces. For example: pipes, radiators, ranges, refrigerator enclosures.

- 8. Keep Children Away**

Do not let visitors contact tool. All visitors should be kept away from work area.

- 9. Store Idle Tools**

When not in use, tools should be stored in a dry, and high or locked-up place — out of reach of children.

- 10. Use Right Tool**

Do not force small tool or attachment to do the job of a heavy duty tool. Do not use tool for purpose not intended — for example — do not use a circular saw for cutting tree limbs or logs.

- 11. Non-Conforming Cutting Tools**

Your Magnetic Drill is designed to use Hougén Cutters. The use of drilling tools having different shank styles is not recommended as they may not tighten securely in the drill arbor with risk of accident or injury.

- 12. Secure Work**

Use clamps or a vise to hold work. It is safer than using your hand and it frees both hands to operate tool.

- 13. Always Wear Safety Glasses or Goggles**

- 14. Dress Properly**

Do not wear loose clothing or jewelry. They might entangle with spinning chips or get caught in moving parts. Rubber gloves and nonskid footwear are recommended when working outdoors. Wear sturdy leather gloves when working indoors.

Wear protective hair covering to contain long hair.

- 15. Do Not Abuse Cord**

Never carry drill unit by its cord or yank it to disconnect from receptacle.

Keep cord away from heat, oil, and sharp edges.

- 16. Do Not Overreach**

Keep proper footing and balance at all time.

- 17. Maintain Tools With Care**

Keep tools sharp and clean for better and safer performance.

Do not use dull or broken Hougén Cutters.

Follow instructions for lubricating and changing accessories.

Keep handles dry, clean, and free from oil and grease.

IMPORTANT SAFETY INSTRUCTIONS - CONTINUED

Continued...

Inspect tool cords periodically and, if damaged, have repaired by authorized service facility. Inspect extension cords periodically and, if damaged, have repaired by authorized service facility.

18. Disconnect Tools

Disconnect when not in use, before servicing, and when changing Houghen Cutters or accessories.

19. Remove Adjusting Keys and Wrenches

Form a habit of checking to see that keys and wrenches are removed from tool before turning it on.

20. Check Damaged Parts

Before further use of the drill, a part that is damaged should be carefully checked to determine that it will operate properly and perform its intended function. Check for alignment of moving parts, binding of moving parts, breakage of parts, mounting, and any other conditions that may affect its operation. A part that is damaged should be properly repaired or replaced by an authorized service center unless otherwise indicated elsewhere in this operator manual. Do not operate tool if switch does not turn it on and off.

21. Stay Alert

Watch what you are doing.
Use common sense.
Do not operate tool when you are tired.
Have defective switches replaced by authorized service center.

22. Outdoor Use Extension Cords

When tool is used outdoors, use only extension cords intended for use outdoors and so marked.

23. Additional Safety Precautions

Spindle and cutter should never be used as a hand-hold.

Keep hands and clothing away from all moving parts. Do not use Houghen Cutters where ejected slug might cause injury (slug ejected at end of cut). Be sure that all safety devices are properly adjusted and in use. Also, adhere to all operating instructions.

Do not drill through any surface that may contain live electrical wiring. Drilling into a live wire could cause exposed metal parts of the drill to be made live. Remove chips wrapped around Houghen Cutter and arbor after each hole. With motor off and power disconnected, grasp chips with leather gloved hand or pliers and pull while rotating counter-clockwise.

Should the cutter become jammed in the work, stop the unit immediately to prevent personal injury. Disconnect the drill from the power supply and loosen jammed cutter by turning the arbor counterclockwise. Never attempt to free the jammed cutter by starting the motor.

Service at authorized repair center only.

24. Operating Near Welding Equipment

It is NOT recommended that you use this tool on the same work surface as an arc welder. This can cause severe damage to the unit, particularly the power cord. This could also result in personal injury to the operator.

25. Safe Electrical Connection

Wet electrical connections are shock hazards. To prevent the cutting fluid from traveling along the cord and contacting the plug or power outlet, tie a drip loop as shown at below. Also elevate extension cords or gang box connections.

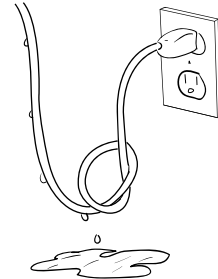

26. Save These Instructions

BEFORE INSTALLING CUTTER

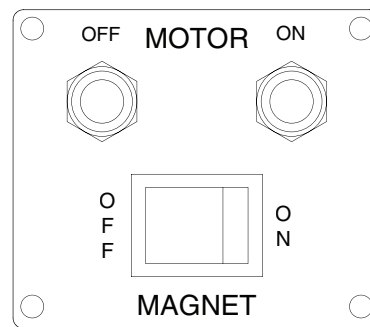

IMPORTANT: Before turning on the machine, it is imperative that the operator understands the interrelated functions of the SAFETY SWITCH, MAGNET SWITCHES, AND MOTOR SWITCHES.

1. Place Magnetic Drill on clean, flat steel plate that is at least 3/8" thick.
2. Plug unit into proper AC power source. **DO NOT use with DC power.**
3. Locate the Magnet ON / OFF switch and the MOTOR ON and OFF switches as shown below.

MOTOR ON SWITCH — Starts the motor (will not function unless the magnetic base is energized and the safety switch is activated).

MOTOR OFF SWITCH — Deactivates motor. Magnetic base remains energized and safety switch activated.

MAGNET ON / OFF-- Energizes - De-energizes the magnetic base. Magnet must be ON to activate the motor.

SAFETY SWITCH — Located in base of drill. Enables motor operation only when magnet is properly seated on a clean and flat work surface. Turns motor off if drill unit should lift occur while cutting.

UNPACKING YOUR NEW MAGNETIC DRILL

1. Open shipping carton and lay the drill case on it's side.
2. Open the case lid and remove the hardware and literature packets.
3. **Read and Follow All Instructions** before attempting to operate your new Magnetic Drill.
4. Complete and mail the Product Registration Card now. It is important that Hougen Manufacturing, Inc. have a record of product ownership.
5. Included with your new Mag Drill are the following parts:
 - 24011 Hub Assembly
 - 01447 Feed Handles (3)
 - 04532 Feed Handle Knobs (3)
 - 10730 Safety Chain
 - 11741 Concentrated Cutting Fluid (Pint)
 - 24166 Hex-Key "T" Handle 7/32"
 - 10727 Allen Wrench 3/16"
 - 13013 Allen Wrench 5/32"
6. Using the handle of Magnetic Drill, lift unit out of the shipping case.
7. Remove all packing and securing material from the drill unit.
8. Your Magnetic Drill was factory adjusted prior to shipping. Check to make sure that all fasteners are snug and have not vibrated loose in transit.
9. Your new Magnetic Drill comes complete with an internal quill/arbor assembly. The 3/4" diameter arbor bore fits all 3/4"- shank "12,000-Series" Hougen Cutters.

Reread Safety Warnings listed in the Operator's Manual and on the drill unit to avoid injury. Follow operating procedures.

USE OF SAFETY CHAIN

The safety chain should be used to prevent the drill unit from falling in the event of a power failure or if the magnet breaks loose from the work surface. The safety chain should be attached to the drill by running it through the "D" ring located at the rear of the magnet, and tightly secured.

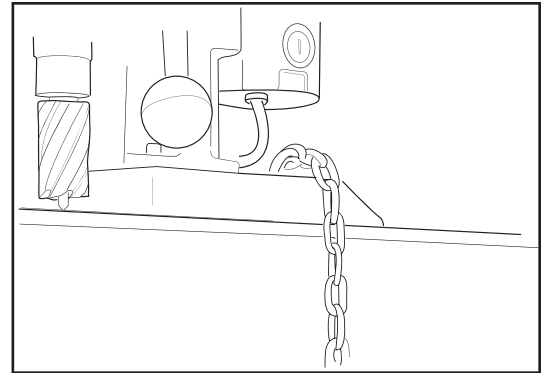

HOUGEN CUTTER INSTALLATION

1. Disconnect from power source.
2. Lay drill on its side with feed handles up or be sure Arbor clears table if unit is in normal operating position.
3. Remove set screws from spindle.
4. Insert proper pilot in shank end of Hougen Cutter. Pilot #24131 is recommended for use with spring loaded ejection on cutters 3/4" diameter and larger.
5. Insert Hougen Cutter until flats on cutter shank are aligned with set screw holes and are exactly perpendicular to axis of set screw holes. If 1/2" diameter shank cutter is used, slip (10851) Arbor Adapter over the cutter shank with adapter hole positioned exactly over flat on cutter shank prior to inserting into Arbor bore.
6. Insert set screws and tighten. Check to be certain that cutter is secure.

INSTALLATION OF CUTTING FLUID BOTTLE

1. With Magnetic Drill in operating position, turn feed handle so that cutter and pilot are above the work surface.
2. Set coolant bottle in carrying handle yoke with valve facing toward the spindle of the drill. Press down to seat nipple into port.
3. Tighten mounting screw on back of coolant bottle.
4. To test cutting fluid flow (with the magnet ON and motor OFF), feed the arbor gently toward the work surface until the pilot is pushed up into the cutter. Open valve on coolant bottle cap. Fluid should filter down onto the work surface through the groove in the pilot.
5. To insure proper cutter lubrication, always make sure that the slot in the pilot is kept clean.

OPERATION OF CUTTING FLUID BOTTLE

1. With Magnetic Drill in operating position, turn feed handle so that cutter and pilot are above the work surface.
2. Turn cutting fluid bottle valve to "OFF" position.
3. Remove bottle cap, fill with cutting fluid and replace cap.
4. Open cap vent by turning knurled screw 2 turns.
5. Test metering capabilities (MAGNET ON - MOTOR OFF) by feeding the Arbor gently toward work surface until pilot is pushed up into Cutter, thus allowing fluid to filter down onto work surface through groove in pilot.

Note: As quill is fed toward material, fluid is drawn from the bottle. As quill is returned to its starting position, fluid will return to the bottle.

Note: Coolant flow has been predetermined. Valve intended for "ON-OFF" operation only. Trying to regulate coolant-flow with valve will cause valve to leak.

See Page 9 for optional Pressurized Coolant Bottle Assembly.

OPERATING INSTRUCTIONS

1. Make sure workpiece and bottom of magnet are free of chips, oil, etc.
2. Secure unit to workpiece with safety chain.
3. Position drill by sliding it and gently feeding Arbor so that pilot point is touching center of hole to be drilled.
4. Turn magnet ON by pressing the MAGNET ON button.
5. Select the proper RPM for the cutter diameter you are using. Use the 450 setting for 7/16" thru 1-1/16" diameter and use the 250 setting for 1-1/8" thru 2-3/8" diameters. Note: The RPM settings for the diameter ranges are to be used as starting points only. Setting may vary per application.
6. Turn Feed Handle, raising the cutter until the pilot is above the work surface.
7. Open the cutting fluid bottle valve.
8. Make certain that cutter is clear of workpiece and turn motor ON by pressing the MOTOR ON button.
9. Feed Hougén Cutter slowly into workpiece. Only after cutting path is established to a depth of about 1/16" can full force be applied to feed handles.
10. Ease up on feed pressure as cutter starts breaking through.
11. At conclusion of cut, turn motor OFF by pressing motor STOP button. Turn Feed Handles to raise Arbor thereby ejecting the slug if it hasn't already fallen free.
12. Close the cutting fluid bottle valve.
13. Turn magnet OFF by pressing the magnet OFF button. As the magnet de-energizes, the rear of the magnet should lift up off the work surface.
14. Disconnect from power source.
15. If necessary, remove chips from cutter and magnet, preferably wearing leather work gloves and/or with pliers.
16. Disconnect safety chain and you are ready to move unit to new drilling position.

Special Instructions for Horizontal or Overhead Operation

1. **Always Use Safety Chain.**
2. Use Hougén Slick-Stick™ (P/N: 11745-6) or animal-fat base solid-lubricant applied liberally to cutter.
3. For horizontal use, apply cutting fluid to external parts of cutter with plastic bottle or oiling can, or use the optional pressurized coolant bottle assembly (P/N 24140).

MAGNET OPERATION

SPECIAL NOTES:

The magnet on the HMD505 is a dual voltage magnet. When turning on the magnet a control voltage is supplied to the magnet. When you turn the motor on, the control voltage is increased to the magnet. This combination provides a better holding power on the work surface.

With this special feature however, it requires that you do not leave the magnet and motor on for extended periods of time. This does not impede the normal performance of your unit. The increased holding power if left on could cause overheating of the unit. Take care of your unit by unplugging your unit when not in use. Failure to follow these special guide lines could cause damage to your unit and therefore result in personal injury.

Always remember that the magnet's holding power is directly related to the workpiece thickness and surface condition. Since magnetic attraction diminishes with thinner material or rough surfaces, mechanical clamping of drill unit to the workpiece should be used when cutting thin material (3/8" or less) or material with uneven surfaces.

HINTS FOR SMOOTHER OPERATION

1. Keep insides of Hougén Cutter clear of chips. Chips will interfere with cutting to maximum depth as well as impede free oil flow from arbor to work and can cause cutter breakage.
2. Keep workpiece, machine, arbor and Hougén Cutter free of chips and dirt.
3. Tighten all bolts regularly.
4. We highly recommend using a light viscosity cutting fluid (preferably RotaMagic™ Cutting Fluid - P/N: 11742-4).
5. Occasionally check metering of cutting fluid flow. Lack of coolant may cause Hougén Cutter to freeze in cut, slug to stick, and may result in poor cutter life.
6. Always start cut with light feed pressure and then increase sufficiently to achieve maximum cutting rate.
7. Ease off on pressure as cutter begins to break through at end of cut.
8. Keep magnet and cutter free of chips and dirt.
9. If slug hangs up in cutter, turn motor off and bring cutter down on flat surface. This will normally straighten a cocked slug, allowing it to be ejected.
10. Cut overlapping holes as illustrated, using minimum steady pressure. When cutter is removing material whose cross-section is half or less than the cutter diameter, pilot should be removed and tool should be fed with care. External lubrication should be used.

NOTE: When cutting in this manner, cutting fluid may escape from the cutting area. Tool should be fed with care, using external lubrication.

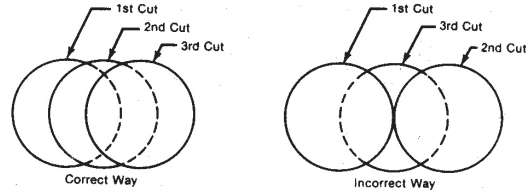

11. When cutting large diameter or deep holes, it may be necessary to stop in the middle of the cut to add cutting fluid to the reservoir and also remove chips from around the arbor. When doing this, do not raise the cutter out of the hole. Doing so can allow chips to get under the teeth of the cutter and make it difficult to restart the cut.

“Babying” the Cutter through the cut will only decrease tool life.

#1 cause of cutter breakage and prematurely dull teeth is too little feed pressure.

RECOMMENDED RPM'S

7/16" - 1-1/16" Diameter	450 RPM
1-1/8" - 2-3/8" Diameter	250 RPM

MAINTENANCE

In order to minimize wear on moving parts and to insure smoother operation and longer life for your magnetic drill, the following maintenance should be done periodically, based on use.

1. Regularly tighten all fasteners and replace any worn components.
2. Check motor brushes and replace if worn.
3. Check power cord and motor cord. If cracked or frayed, return to authorized repair center for replacement.

HMD505 MOTOR - 04631

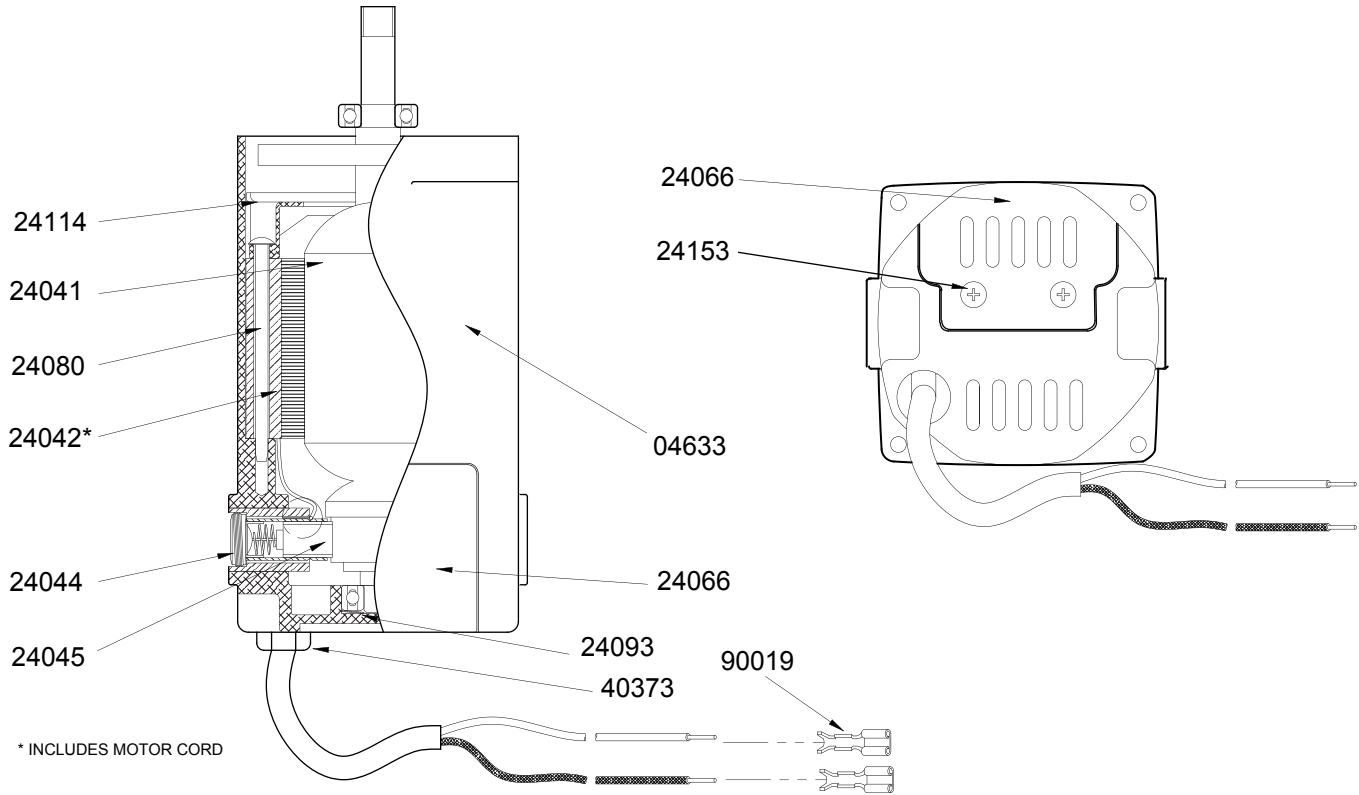

Part #	Description	Qty
04633	Motor Housing Assy	1
24041	Armature	1
24042	Field	1
24044	Cap for Brush	2
24045	Brush (Package of 2)	1
24066	Access Door	1
24080	Screw Self Tapping #10 x 3-1/4	2
24093	Spring Washer	1
24114	Motor Baffle	1
24153	Screw Self Tapping	2
40373	Strain Relief	1
90019	Terminal	2

ARBOR ASSEMBLY - 24199

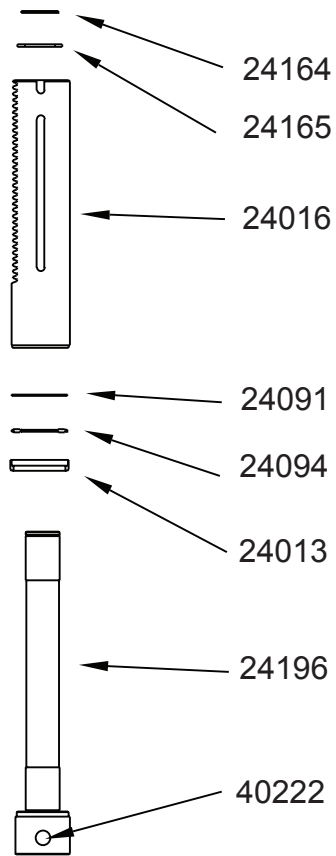

Part #	Description	Qty
24013	Thrust Bearing Seal	1
24016	Quill	1
24091	Thrust washer	1
24094	Thrust Needle Bearing	1
24164	LH Retaining Ring	1
24165	Washer	1
24196	Arbor	1
40222	Set Screw	2

OPTIONAL PRESSURIZED COOLANT BOTTLE 24140

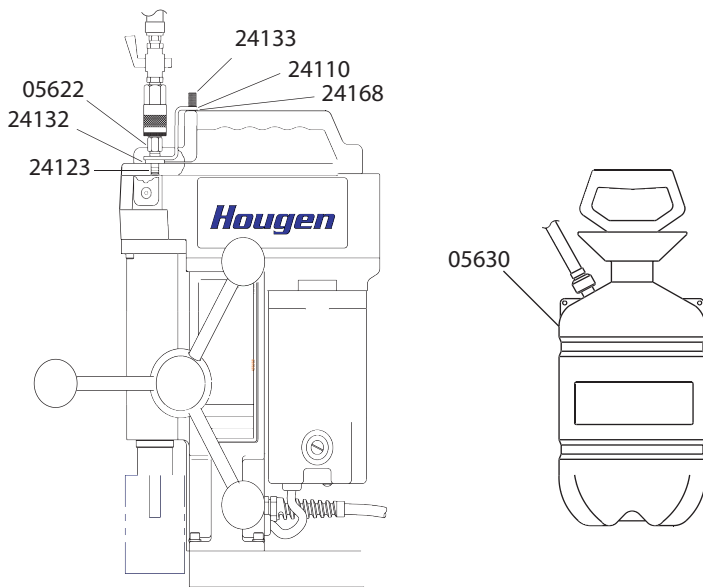

Part #	Description	Qty
05622*	QUICK CONNECT	1
05630*	COLLANT BOTTLE ASSY	1
24110*	SCREW, CAPTIVE	1
24123*	"O" RING	1
24132*	ADAPTER	1
24133*	BRACKET	1
24168*	NYLON FLAT WASHER	1

* PARTS INCLUDED WITH 24140

HMD505 PANEL PARTS

PANEL ASSEMBLY END (04613)

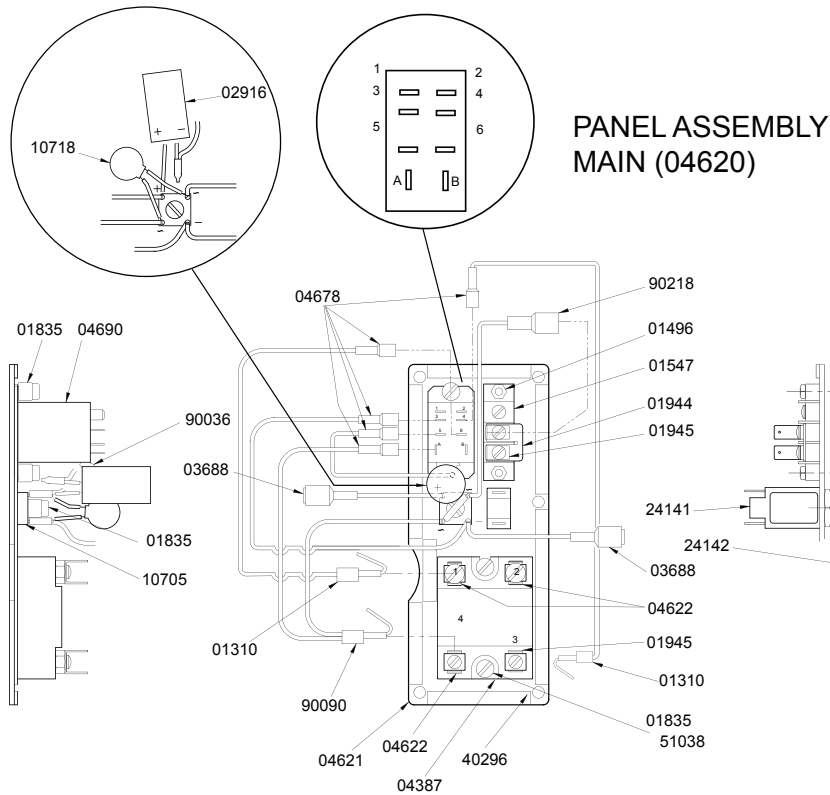
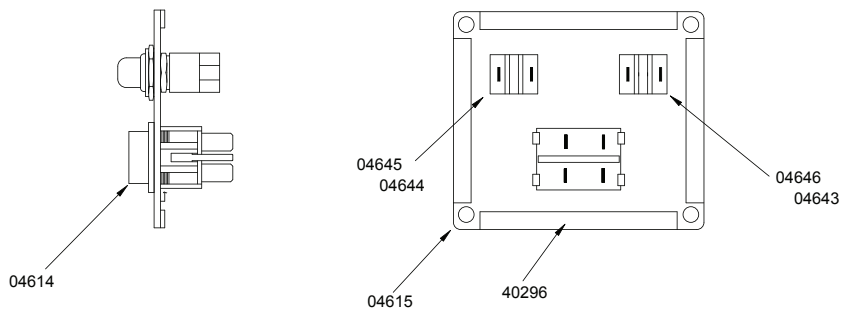

Part #	Description	Qty
01310	Terminal Piggy Back	2
01496	Spacer	2
01547	Terminal Strip	1
01835	Nylon Nut	5
01944	Terminal Jumper	1
01945	Terminal Spade	3
02916	Capacitor	1
03688	Terminal Male Insulator	2
04387	Relay 240V	1
04614	Rocker Switch	1
04615	Faceplate End	1
04621	Faceplate Front	1
04622	Double Terminal	3
04643	Red Seal	1

Part #	Description	Qty
04644	Green Seal	1
04645	Switch On	1
04646	Switch Off	1
04678	Terminal Female Insulator	1
04690	Relay 15A	1
10705	Rectifier	1
10718	Surge Suppressor	1
24141	Circuit Breaker 14A	1
24142	Cover	1
40296	Sponge Seal	1
51038	Flat Washer #6	2
90036	Adhesive	1
90090	Terminal Piggy Back	1
90218	Terminal Female	1

HMD505 HOOK UP DIAGRAM

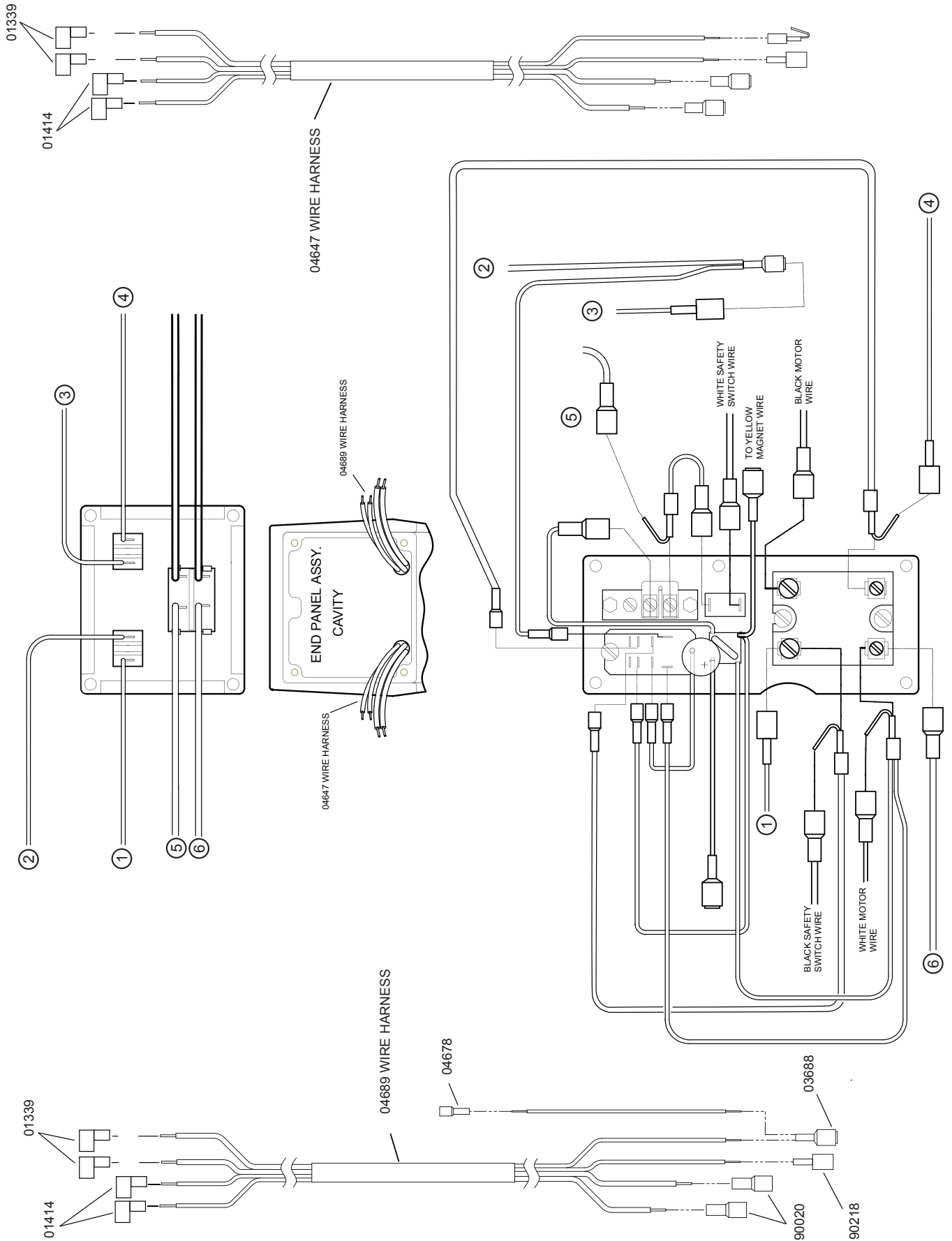

HOUGEN HMD505 EXPLODED VIEW

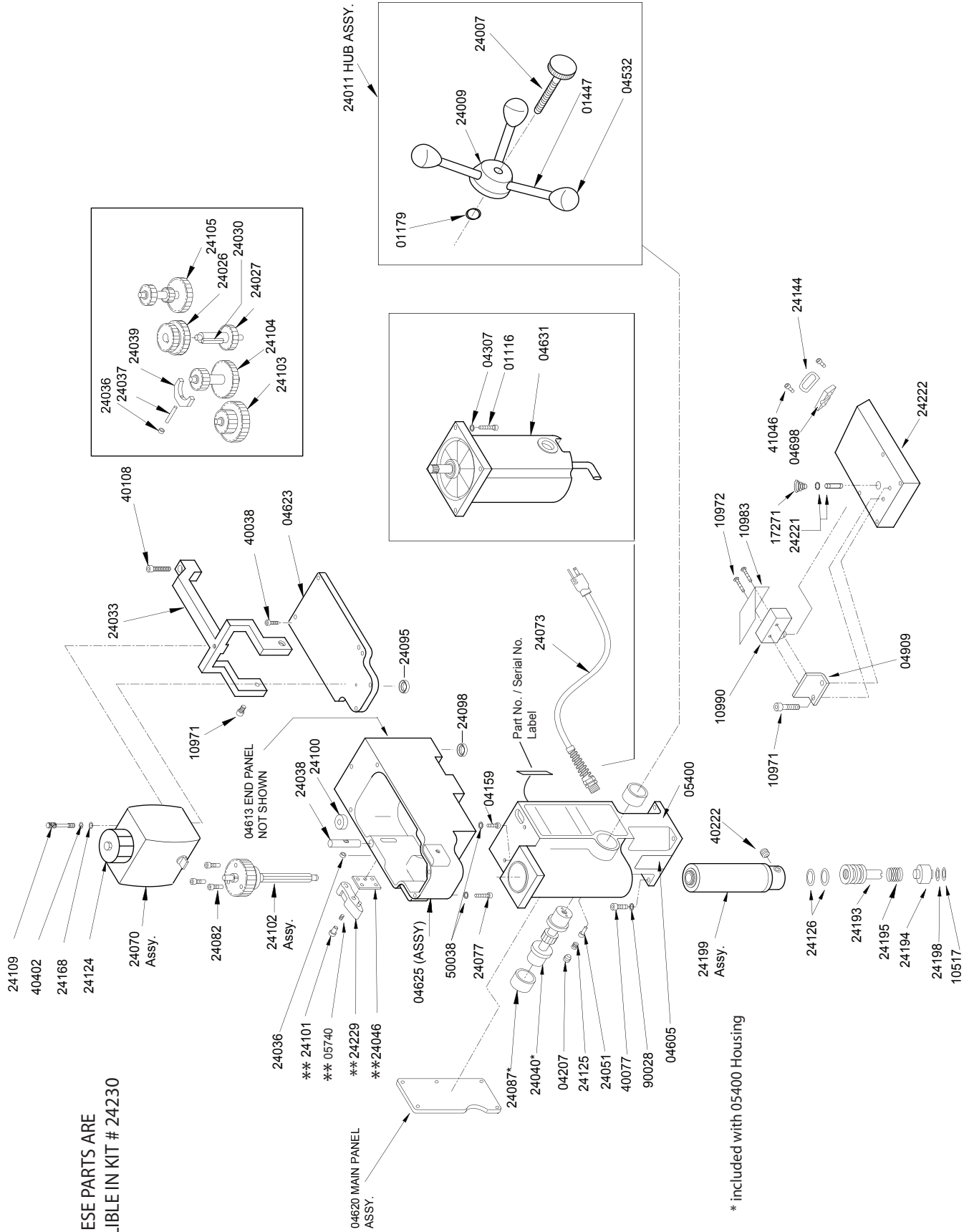

**** THESE PARTS ARE AVAILABLE IN KIT # 24230**

* included with 05400 Housing

HMD505 DRILL PARTS LIST

Part #	Description	Qty	Part #	Description	Qty
01116	Screw SHC #10-32	4	24046	Gear Switch Plate	1
01179	O-Ring	1	24051	Quill Stop	1
01447	Feed Handle	3	24070	Coolant Bottle Assy.	1
04157	Screw FHSCC #10-32	2	24073	Power Cord Assy	1
04158	Screw Self Thd #10-24	1	24077	Screw SHC #10-32	4
04159	Screw LHSCS #10-32	2	24082	Screw SHC #6-32	3
04207	Screw SOC Set 3/8-16	1	24087	Bearing Bush	2
04307	Flat Washer #10	4	24092	Spring Washer	1
04532	Feed Knob	3	24095	Lip Seal (Gear Cover Cap)	1
04605	Plate	1	24096	Lip Seal (Armature Shaft)	1
04623	Cover & Bearing Assy	1	24100	Ball Bearing	9
04631	Motor Assy	1	24101	Screw SHSLD 1/4"	1
04640	Gear Box Housing	1	24102	Spline Shaft	1
04647	Wire Assy	1	24103	Spur Gear & Shaft	1
04689	Wire Assy	1	24104	Spur Gear & Shaft	1
04698	Chain Plate	1	24105	Spur Gear & Shaft	1
04909	Safety Switch Bracket	1	24109	Screw - Capt. Thumb	1
05400	Housing Assy	1	24124	Cap-Coolant Bottle	1
05740	Spring Compressed	1	24125	Compression Spring	1
10517	Retaining Ring	1	24126	O-Ring	2
10560	Washer #10-Ext	1	24143	Spring Plate	1
10727	Allen Wrench 3/16	1	24144	Ring-D	1
10730	Chain Assy	1	24159	Gear Switch & Plunger	1
10971	Screw SHC 1/4-20	2	24166	Hex Key T-Handle	1
10972	Screw BHC #6-32	2	24167	Compression Spring	2
10983	Microswitch Shield	1	24193	Spline Extension	1
10990	Safety Switch	1	24194	Spring Plunger	1
13013	Allen Wrench 5/32	1	24195	Compression Spring	1
17271	Compression Spring	1	24198	Lip Seal	1
24007	Knob for Feed Hub	1	24199	Quill & Arbor	1
24009	Feed Hub	1	24221	Plunger Assy	1
24011	Feed Hub Assy	1	24222	Magnet Assy	1
24013	Thrust Bearing Seal	1	24229	Handle Assembly	1
24026	Gear 32 & 39 Tooth	1	40038	Screw SHC #10-32	6
24027	Gear & Shaft Assy #2	1	40077	Screw SHC 1/4-20	4
24030	Key 3/16"	1	40108	Screw-SHC 1/4-20	1
24033	Carrying Handle	1	40402	Washer Flat	1
24036	Washer-Gear Shift	2	41044	Screw BHC #10-32	9
24037	Dowel Pin 3/16"	1	41046	Screw SHC #10	4
24038	Gear Shift Pin	1	50038	Washer Heli-Lock	4
24039	Gear Shift Yolk	1	90028	Washer Heli 1/4"	4

“12,000-SERIES” HOUGEN CUTTERS

Cutter Dia. (Inches)	Decimal Equivalent	Part No.		
		1" D.Q.C.	2" D.Q.C.	3" D.Q.C.
Use with Pilot		10531	10532	
7/16	.4375	12114	12214	----
Use with Pilot		10533	10534	
1/2	.5000	12116	12216	----
9/16	.5625	12118	12218	----
5/8	.6250	12120	12220	----
11/16	.6875	12122	12222	----
Use with Pilot		10527	10528	24131
3/4	.7500	12124	12224	3-12224
13/16	.8125	12126	12226	3-12226
7/8	.8750	12128	12228	3-12228
15/16	.9375	12130	12230	3-12230
1	1.0000	12132	12232	3-12232
1-1/16	1.0625	12134	12234	3-12234
1-1/8	1.1250	12136	12236	3-12236
1-3/16	1.1875	12138	12238	3-12238
1-1/4	1.2500	12140	12240	3-12240
1-5/16	1.3125	12142	12242	3-12242
1-3/8	1.3750	12144	12244	3-12244
1-7/16	1.4375	12146	12246	3-12246
1-1/2	1.5000	12148	12248	3-12248
1-9/16	1.5625	12150	12250	3-12250
1-5/8	1.6250	12152	12252	3-12252
1-11/16	1.6875	12154	12254	3-12254
1-3/4	1.7500	12156	12256	3-12256
1-13/16	1.8125	12158	12258	3-12258
1-7/8	1.8750	12160	12260	3-12260
1-15/16	1.9375	12162	12262	3-12262
2	2.0000	12164	12264	3-12264
2-1/16	2.0625	----	12266	----
2-1/8	2.1250	----	12268	----
2-3/16	2.1875	----	12270	----
2-1/4	2.2500	----	12272	----
2-5/16	2.3125	----	12274	----
2-3/8	2.3750	----	12276	----

Cutter Dia. (Metric)	Decimal Equivalent	Part No.		
		1" D.Q.C.	2" D.Q.C.	3" D.Q.C.
Use with Pilot		10531	10532	
12mm	.4724	12312	12412	----
Use with Pilot		10533	10534	
13mm	.5118	12313	12413	----
14mm	.5512	12314	12414	----
15mm	.5906	12315	12415	----
16mm	.6299	12316	12416	----
17mm	.6693	12317	12417	----
18mm	.7087	12318	12418	----
Use with Pilot		10527	10528	24131
19mm	.7480	12319	12419	12519
20mm	.7874	12320	12420	12520
21mm	.8268	12321	12421	12521
22mm	.8661	12322	12422	12522
23mm	.9055	12323	12423	12523
24mm	.9449	12324	12424	12524
25mm	.9843	12325	12425	12525
26mm	1.0236	12326	12426	12526
27mm	1.0630	12327	12427	12527
28mm	1.1024	12328	12428	12528
29mm	1.1417	12329	12429	12529
30mm	1.1811	12330	12430	12530
31mm	1.2205	12331	12431	12531
32mm	1.2598	12332	12432	12532
33mm	1.2992	12333	12433	12533
34mm	1.3386	12334	12434	12534
35mm	1.3779	12335	12435	12535
36mm	1.4173	12336	12436	12536
37mm	1.4567	12337	12437	12537
38mm	1.4961	12338	12438	12538
39mm	1.5354	12339	12439	12539
40mm	1.5743	12340	12440	12540
41mm	1.6142	12341	12441	12541
42mm	1.6535	12342	12442	12542
43mm	1.6929	12343	12443	12543
44mm	1.7323	12344	12444	12544
45mm	1.7717	12345	12445	12545
46mm	1.8110	12346	12446	12546
47mm	1.8504	12347	12447	12547
48mm	1.8898	12348	12448	12548
49mm	1.9291	12349	12449	12549
50mm	1.9685	12350	12450	12550
51mm	2.0079	12351	12451	12551
52mm	2.0472	12352	12452	12552

Commercial / Industrial Limited Warranty

Hougen Manufacturing, Incorporated warrants its Portable Magnetic Drills and its Electro-hydraulic Hole Punchers for a period of 1 year and other products for ninety (90) days from date of purchase against defects due to faulty material or workmanship and will repair or replace (at its option) without charge any items returned. This warranty is void if the item has been damaged by accident or unreasonable use, neglect, improper service, or other causes not arising out of defects in material or workmanship. No other expressed warranty is given or authorized. Hougen Manufacturing, Inc. disclaims any implied warranty of MERCHANTABILITY or FITNESS for any period beyond the expressed warranty and shall not be liable for incidental or consequential damages. Some states do not allow exclusions of incidental or consequential damages or limitation on how long an implied warranty lasts and, if the law of such a state governs your purchase, the above exclusion and limitation may not apply to you. This warranty gives you specific legal rights and you may also have other rights which vary from state to state.

To obtain warranty service, return the item(s), transportation prepaid, to your nearest Factory Authorized Warranty Repair Center or to Hougen Manufacturing, Inc., 3001 Hougen Drive, Swartz Creek, Michigan 48473.

Hougen Drills are warranted against manufacturing defects only. Subject to Hougen Manufacturing inspection.

THIS WARRANTY IS IN LIEU OF ANY OTHER WARRANTY, EXPRESSED OR IMPLIED, INCLUDING ANY WARRANTY OF MERCHANTABILITY OR FITNESS FOR A PARTICULAR PURPOSE.

© 2007 Hougen Manufacturing, Inc.

This product is covered under the following U.S. patent: 5902076

Photographs and Specifications shown are accurate in detail at time of printing. Manufacturer reserves the right to make improvements and modifications without prior notice.

Hougen and the Hougen logo are proprietary trademarks of Hougen Manufacturing Inc.