

08190 SPINDLE ADAPTER KIT

For use on Hougen Drill Model HMD917

The 08190 Adapter Kit is to be used to install a Drill Chuck (sold separately) onto a HMD917 "Slot Drive" spindle.

- 1** Locate and remove the 1/4-28 x 1/4 Button Head Cap Screw from the Coolant Inducer with a 5/32" Hex Wrench.

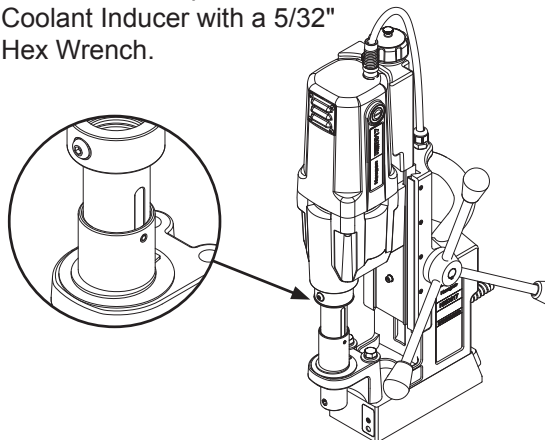

2

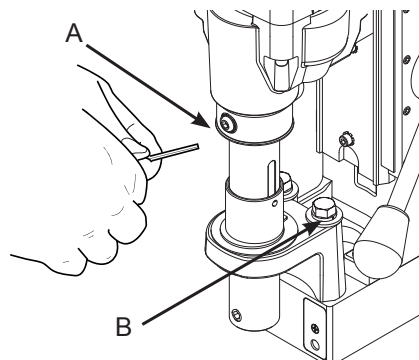

Rotate the Arbor Body so the 5/16-18 X 3/8 set screw inside, aligns with the hole in the Coolant inducer. Insert the 5/32" Hex Wrench and turn the inside set screw 1 full turn counterclock-wise or until loose.

3

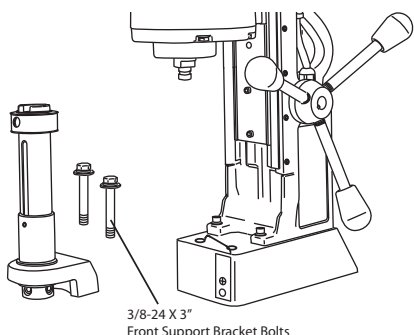

3/8-24 X 3"
Front Support Bracket Bolts

Remove both 3/8-24 X 3" Hex Bolts from the Front Support Bracket using a 9/16" wrench. Now the entire Arbor Body Assembly can be removed.

4

To install the chuck, slide the Spindle Adapter (08188) up onto the Motor Spindle verifying the Spindle sits down in the slot of the Adapter. Install and tighten the 5/16-18 x 3/8 Set Screw (40256), supplied in the kit. Thread the Chuck onto the bottom of the Adapter until hand tight.

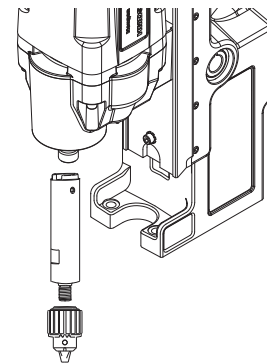

08190 SPINDLE ADAPTER KIT

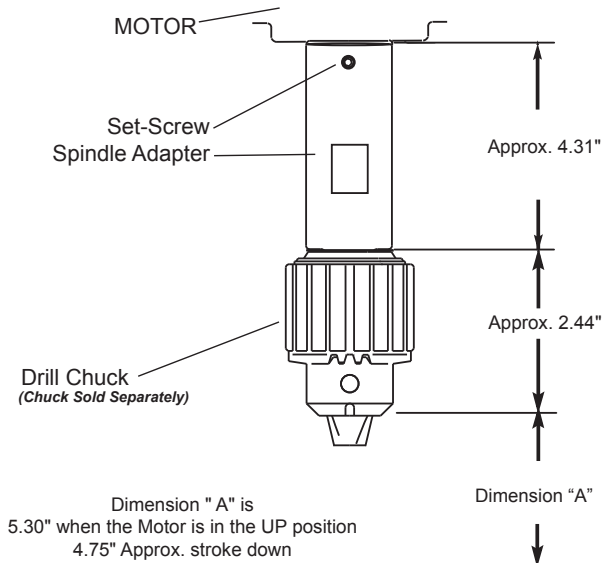

Hougen Manufacturing, Inc.
P.O. Box 2005 • Flint, MI 48501-2005
3001 Hougen Drive • Swartz Creek, MI 48473
Phone (810) 635-7111 • Fax (810) 635-8277
www.hougen.com • info@hougen.com
© 2014 Hougen Manufacturing, Inc.